

# **Stevens® Electro ChartDrive**

**INSTRUCTION 90079A  
MARCH 1994**



# Table of Contents

---

<b>1 INTRODUCTION</b> .....	<b>1</b>
1.1 GENERAL DESCRIPTION .....	1
1.2 SAFETY INFORMATION .....	2
1.3 PRINCIPLES OF OPERATION .....	2
1.4 ELECTRO CHARTDRIVE SPECIFICATIONS .....	3
<b>2 INSTALLATION</b> .....	<b>5</b>
2.1 MECHANICAL INSTALLATION .....	5
2.2 ELECTRICAL INSTALLATION.....	7
<b>3 OPERATION</b> .....	<b>10</b>
3.1 GENERAL DESCRIPTION .....	10
3.2 OPERATION IN "ECD SAMPLE" MODE.....	10
3.3 OPERATION IN "ECD LISTEN".....	12
3.4 OPERATION IN "DUAL SAMPLE" MODE .....	13
3.5 OPERATION OF THE TEST PUSH BUTTON .....	14
3.6 OPERATION OF THE PULSE OUTPUTS .....	14
3.7 SERIAL COMMAND SUMMARY.....	14
3.7.1 <b>AS</b> Command (Set SDI-12 Sensor Address) .....	14
3.7.2 <b>CO</b> Command (Send ECD configuration) .....	15
3.7.3 <b>CR</b> Command (Set current ECD reading) .....	16
3.7.4 <b>DR</b> Command (Set motor direction) .....	16
3.7.5 <b>DS</b> Command (Set Dual Sample rate) .....	17
3.7.6 <b>HE</b> Command (Help) .....	18
3.7.7 <b>MO</b> Command (Enter motor offset adjustment) .....	18
3.7.8 <b>MS</b> Command (Set motor scaling) .....	19
3.7.9 <b>SM</b> Command (Set Sample Mode) .....	20
3.7.10 <b>SR</b> Command (Set ECD sample rate) .....	21
3.7.11 <b>SW</b> Command (Send software revision) .....	21
<b>4 MAINTENANCE</b> .....	<b>22</b>
<b>5 TROUBLESHOOTING</b> .....	<b>23</b>
<b>6 TECHNICAL NOTES</b> .....	<b>24</b>
6.1 GENERAL DESCRIPTION .....	24
6.2 NORMAL OPERATING MODES .....	24
6.3 COMMAND MODE .....	24
6.4 MONITOR MODE .....	24
6.5 SDI-12 TRANSPARENT MODE .....	25
6.6 INITIAL CONDITIONS .....	25
<b>ILLUSTRATIONS</b>	
Figure 1. Electro ChartDrive .....	1
Figure 2. Electro ChartDrive Mounting .....	6
Figure 3. ECD Component Locations .....	8
Figure 4. System Configuration Diagrams .....	9

# Safety and Equipment Protection

---

## **WARNING!**

ELECTRICAL POWER CAN RESULT IN DEATH, PERSONAL INJURY OR CAN CAUSE DAMAGE TO EQUIPMENT.

If the instrument is driven by an external power source, disconnect the instrument from that power source before attempting any repairs.

## **WARNING!**

BATTERIES ARE DANGEROUS. IF HANDLED IMPROPERLY, THEY CAN RESULT IN DEATH, PERSONAL INJURY OR CAN CAUSE DAMAGE TO EQUIPMENT.

Batteries can be hazardous when misused, mishandled, or disposed of improperly. Batteries contain potential energy, even when partially discharged.

## **WARNING!**

ELECTRICAL SHOCK CAN RESULT IN DEATH OR PERSONAL INJURY.

Use extreme caution when handling cables, connectors, or terminals; they may yield hazardous currents if inadvertently brought into contact with conductive materials, including water and the human body.

## **CAUTION!**

Be aware of protective measures against environmentally caused electric current surges. Read the Leupold & Stevens Engineering Applications Note, *Surge Protection of Electronic Circuits*, publication number 42147.

In addition to the previous warnings and cautions, the following safety activities should be carefully observed.

# Safety and Equipment Protection

---

## Children, Adolescents

NEVER give batteries to young people who may not be aware of the hazards associated with batteries and their improper use or disposal.

## Jewelry, Watches, Metal Tags

To avoid severe burns, NEVER wear rings, necklaces, metal watch bands, bracelets, or metal identification tags near exposed battery terminals.

## Heat, Fire

NEVER dispose of batteries in fire or locate them in excessively heated spaces. Observe the temperature limit listed in the instrument specifications.

## Charging

NEVER charge "dry" cells or lithium batteries that are not designed to be charged.

NEVER charge rechargeable batteries at currents higher than recommended ratings.

NEVER recharge a frozen battery. Thaw it completely at room temperature before connecting charger.

## Unvented Container

NEVER store or charge batteries in a gas-tight container. Doing so may lead to pressure buildup and explosive concentrations of hydrogen.

## Short Circuits

NEVER short circuit batteries. High current flow may cause internal battery heating and/or explosion.

# Safety and Equipment Protection

---

## Damaged Batteries

Personal injury may result from contact with hazardous materials from a damaged or open battery. NEVER attempt to open a battery enclosure. Wear appropriate protective clothing, and handle damaged batteries carefully.

## Disposal

ALWAYS dispose of batteries in a responsible manner. Observe all applicable federal, state, and local regulations for disposal of the specific type of battery involved.

## **NOTICE**

Leupold & Stevens, Inc. makes no claims as to the immunity of its equipment against lightning strikes, either direct or nearby.

The following statement is required by the Federal Communications Commission:

WARNING - This equipment generates, uses, and can radiate radio frequency energy and, if not installed in accordance with the instructions manual, may cause interference to radio communications. It has been tested and found to comply with the limits for a Class A computing device pursuant to Subpart J of Part 15 of FCC Rules, which are designed to provide reasonable protection against such interference when operated in a commercial environment. Operation of this equipment in a residential area is likely to cause interference in which case the user at his own expense will be required to take whatever measures may be required to correct the interference.

## **USER INFORMATION**

Leupold & Stevens, Inc., makes no warranty as to the information furnished in these instructions and the reader assumes all risk in the use thereof. No liability is assumed for damages resulting from the use of these instructions. We reserve the right to make changes to products and/or publications without prior notice.

# 1 Introduction

---

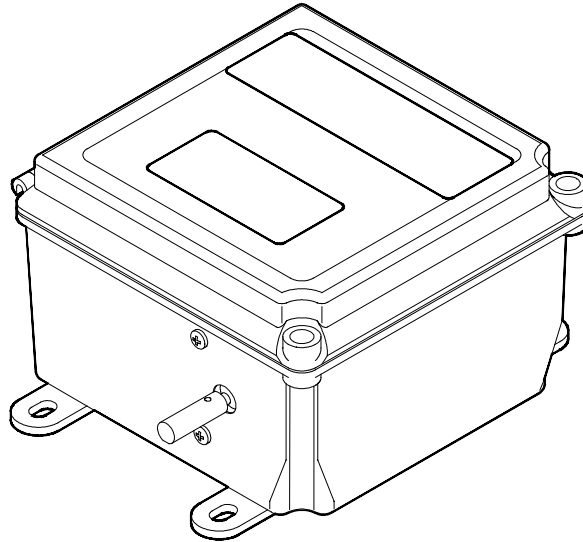

Figure 1 Electro ChartDrive

## 1.1 GENERAL DESCRIPTION

The Electro ChartDrive (ECD) is an instrument that interprets signals on a Serial Digital Interface (SDI-12) communications line and provides a mechanical output for driving a Stevens Chart Recorder and electrical outputs for a Stevens data logger. It is housed in a glass-filled polyester NEMA 4 enclosure, supplied with brackets for mounting on the bench beside the recorder. The ECD and recorder are mechanically connected with sprockets and a looped length of chain.

The internal circuitry uses a CMOS microprocessor-based design, for operation over a wide temperature range. Careful design provides low current operation and long life from remote battery supplies. A low-power stepping motor is used as the output device, assuring accurate and repeatable positioning of the output drive shaft.

# 1 Introduction

---

Provisions are made to operate stand-alone with an SDI-12 sensor, or as part of a larger SDI-12 system. The ECD is particularly well-suited for operation with the Paroscientific, Inc. PS-2 Digiquartz® Intelligent Transmitter, providing a highly-accurate local chart record of water level. Together, they are the ideal replacement for a mercury manometer.

## 1.2 SAFETY INFORMATION

Before performing any procedure in this manual, read all applicable warnings and cautions.

## 1.3 PRINCIPLES OF OPERATION

The signal from the SDI-12 data line contains a digitally-encoded representation of the physical parameter being measured. This encoded message is stored and compared with the previously-received and stored message. The difference between message values causes the stepping motor to rotate in the appropriate direction with the number of steps that represents that difference. When there is no activity on the SDI-12 line, the circuit remains in a "sleep" mode, requiring very little current. When activity is called for, the circuit "wakes up", advances the stepping motor, and returns to the "sleep" mode.

The ECD may be configured in an "ECD Sample", "ECD Listen" or "Dual Sample" operating mode. In the "ECD Sample" mode, it is connected only to an SDI-12 sensor, with the ECD acting as the controller for the system. An internal electronic timer, with user-selected time intervals, wakes the system and updates the information on a periodic basis. The address of the ECD may be selected to match that of the connected SDI-12 sensor. In the "ECD Listen" mode, the ECD is connected to a larger SDI-12 system, with another instrument acting as the system controller. Then, the ECD listens for the selected sensor address on the SDI-12 line and "intercepts" the data reading as it is transmitted to the system controller. The "Dual Sample" mode enables both the ECD and another controller to sample one or more sensors on the SDI-12 bus.

# 1 Introduction

---

All ECD circuitry is contained on one circuit board in a NEMA 4 enclosure, with a hinged lid which is held closed against a gasket by two screws. SDI-12 connections are through waterproof bushings to a connector inside the enclosure. Programming is done with a terminal or computer, connected to a 9-pin "D" connector inside the enclosure, separate from the SDI-12 connector. The computer must be running a terminal emulation program, such as Stevens® MODTERM.

## 1.4 ELECTRO CHARTDRIVE SPECIFICATIONS

**Data input channel:** Standard SDI-12 interface with serial data, ground, 12 volts and two pulse outputs on a 5-position screw-clamping type of removable connector. Two waterproof cable strain relief bushings are provided in the enclosure, allowing for two separate cables.

**Range:**  $\pm 999.99$  feet (English) or  $\pm 99.999$  meters (metric).

**Serial channel:** Serial ASCII through 9-pin female "D" connector at 0 and 5 volt logic levels; accepts EIA-232 input voltage levels.

**Data format, serial channel:** 7 data bits, 1 stop bit, even parity.

**Data rate:** 1200 bits per second.

**Mechanical output:** Bi-directional shaft rotation, with selectable output ratios of 1.0, 1.5 or 3 feet (English) or 300, 375 or 750 mm (metric) of water level change per shaft revolution. Output torque is 4 oz-in, typical. The physical output is a 3/16 (0.1875) inch diameter, flatted shaft. The provided adapter bushing allows mounting a chain sprocket that fits a 3/8 inch diameter shaft.

**Electronic output:** Directional pulse for each 0.005 ft. (English) or 1 mm (metric) of level change. Outputs are open-collector NPN transistors, switched to signal common for 1 millisecond for each pulse.

# 1 Introduction

---

**Internal timer:** Quartz crystal-controlled, battery-backed. Selectable sampling intervals for the "ECD Sample" or "Dual Sample" modes are 5, 15 or 30 seconds, 1, 2, 5, 15 or 30 minutes, or 1 hour. In "ECD Listen" mode, the ECD will update automatically, as determined by the connected SDI-12 Log-ger.

**CAUTION!** The ECD does not go into a "sleep" mode for the 5, 15 or 30 second Sample Rates.

**Power:** Voltage: 10 to 17 volts d.c.; Current less than 1 mA during "sleep" mode, 80 mA typical when "awake" and 330 mA typical with motor running (at 12 volts). The ECD remains "awake" while the stepping motor rotates an amount equivalent to the data change that occurred between sampling intervals.

**Environment:**

Operating temperature: -4 to 140°F (-20 to 60°C) standard;  
-40 to 160°F (-40 to 71°C) optional (special lubricant)

Relative Humidity: 0 to 95%, non-condensing; operates in condensing conditions with fresh desiccant in the sealed enclosure.

**EMI:** This equipment complies with the requirements in Part 15 of FCC Rules for a Class A computing device. Operation of this equipment in a residential area may cause unacceptable interference to radio and TV reception, requiring the operator to take whatever steps are necessary to correct the interference.

**Physical:** Size: 4.5 x 7 x 8 in (114 x 178 x 203 mm); less than 2.9 lb (1.3 kg)

## 2 Installation

---

The ECD is located close to an SDI-12 sensor or system, and a Stevens chart recorder. A Stevens Telemark II, Pulse Logger or MultiLogger with digital input board may also be connected to the ECD pulse outputs. Power for the ECD is from the same nominal 12 volt d.c. source used by the associated instruments. Space for the ECD must be provided directly adjacent to the chart recorder so the associated drive sprocket and looped length of chain can be used to connect the instruments.

### 2.1 MECHANICAL INSTALLATION

1. Unpack the ECD and examine for any shipping damage. If there is any apparent damage, contact the shipping agency for their recommendations. Also contact Stevens for replacement of the unit. Mount the supplied adapter bushing on the motor shaft. Mount the supplied mounting brackets on the bottom of the enclosure as shown in Figure 2.
2. For new installations, the ECD is supplied with optional sprockets and chain to connect the ECD to the recorder. If it is a replacement for an existing manometer, use the existing manometer output sprocket by mounting it to the bushing adapter on the motor shaft.
3. Place the ECD beside the chart recorder, with the output sprocket facing you. Line up the ECD and recorder sprockets and loop the chain around both of them. Position the ECD so the chain has a small amount of slack, align the sprockets and mark the mounting surface through the center of the holes in the mounting brackets with a pencil.
4. Temporarily remove the ECD and prepare the mounting surface for the type of mounting hardware to be used (e.g. wood screws, etc.). Place the ECD back in position and loosely install the mounting hardware. Position the ECD so the sprockets are directly in line, with a small amount of chain slack, and tighten the mounting hardware. This completes the mechanical installation.

## 2 Installation

---

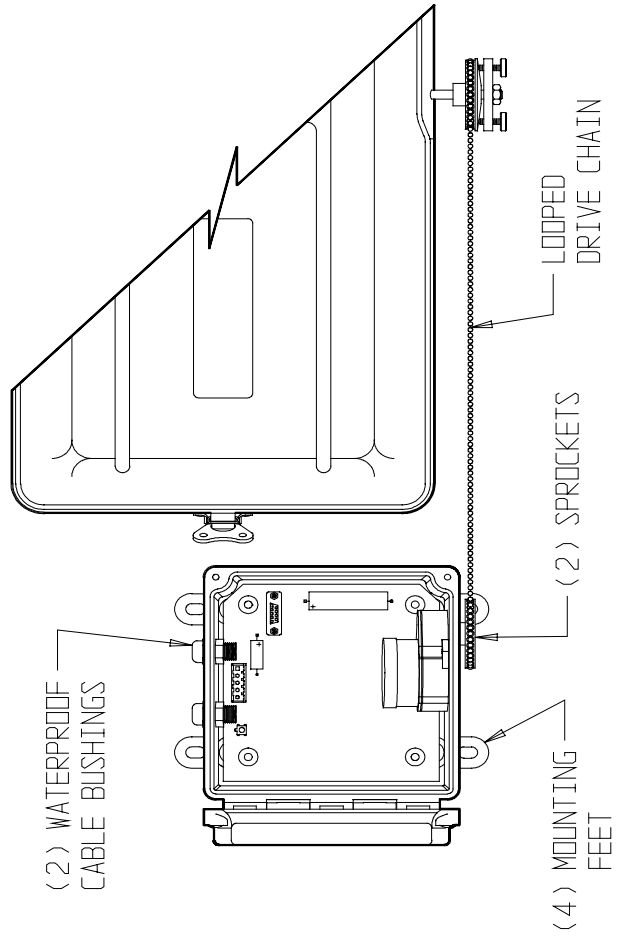

Figure 2 Electro ChartDrive Mounting

# 2 Installation

---

## 2.2 ELECTRICAL INSTALLATION

1. Open the hinged ECD cover by loosening the two screws; it is not necessary to remove them completely. The SDI-12 connector has 5 positions, with the signal names marked alongside; the Serial Port "D" connector has nine positions. See Figure 3 for locations.

2. Install the second supplied waterproof cable strain relief bushing if two cables are connected to the the ECD. This may occur where the ECD is installed with more than one SDI-12 instrument or where the ECD is used as a junction to connect system power. To install the cable bushing, remove the existing hole plug and screw the bushing in its place. Tighten the inner nut of the bushing against the enclosure to form a watertight seal.

### **WARNING: REMOVE SYSTEM POWER BEFORE PERFORMING THESE STEPS!**

3. Insert the SDI-12 cable(s) through the waterproof cable bushings(s) from the outside. Refer to the SDI-12 instrument instructions for correct wire identification. The use of two cables means that there will be more than one wire in a connector position. Remove the signal connector from the circuit board. Strip approximately 1/4 inch (6 mm) of insulation from each wire, insert them into the appropriate connector positions and tighten the screws. Plug the connector into the circuit board again. Refer to the signal names below, as marked on the circuit board:

Connector <u>Name</u>	Signal <u>Description</u>
DATA	SDI-12 Serial Data (Input/Output)
PWR	Power (+12V volts)
GND	Signal/Power Ground (Common)
UP	"Up" Pulse (Output to Stevens logger)
DWN	"Down" Pulse (Output to Stevens logger)

SDI-12 signals only require connecting to DATA, PWR and GND. Pulse outputs to a Stevens Logger require connecting to UP, DWN, PWR, and a common signal connection between the two instruments to GND. See *Figure 4 System Configuration Diagrams*.

## 2 Installation

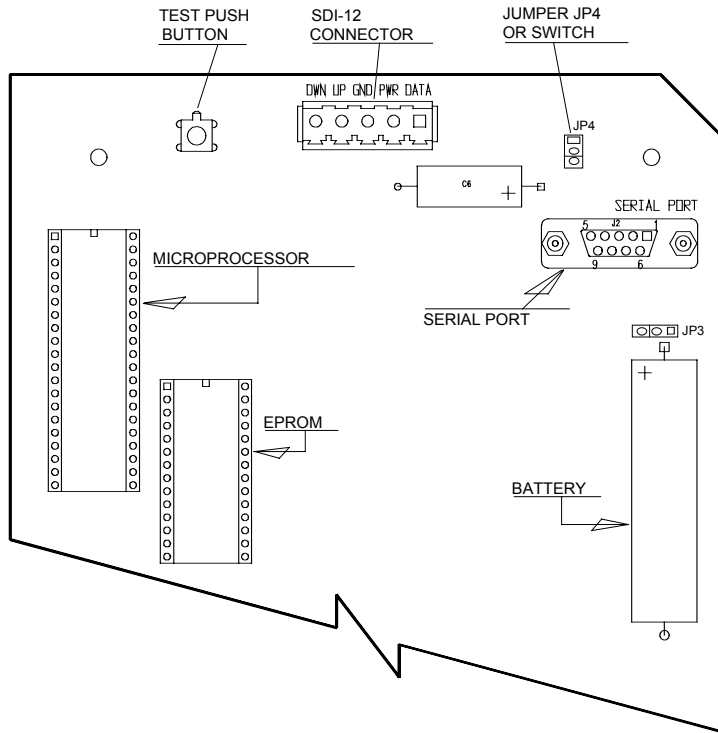
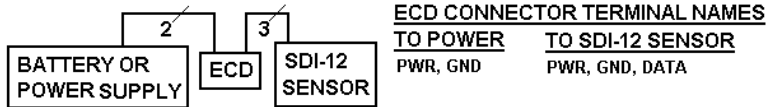

Figure 3 ECD Component Locations

4. Leave a little slack in the signal cables inside the enclosure and tighten the outer nut(s) on the waterproof cable bushing(s). NOTE: To maintain good resistance to moisture, use round, jacketed signal cable with an outer diameter range from 0.090 to 0.265 inches (2.3 to 6.7 mm). This completes the electrical installation.

## 2 Installation

**a. ECD WITH SDI-12 SENSOR**



**b. ECD WITH SDI-12 SENSOR AND STEVENS DATA LOGGER**

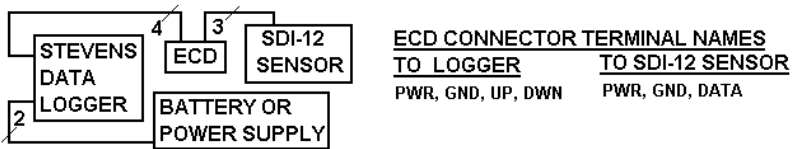

**c. ECD WITH SDI-12 SENSOR AND LOGGER**

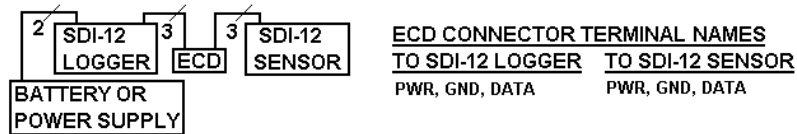

NOTE: Numerals adjacent to thin lines indicate quantity of wires in cables.

Figure 4 System Configuration Diagrams

# 4 Maintenance

---

## 3.1 GENERAL DESCRIPTION

The ChartDrive (ECD) is set up by connecting a terminal or IBM compatible computer to the 9-pin "D" connector on the circuit board. The computer must have a serial port and be running a terminal emulation program, such as Stevens® MODTERM. For those computers with a 9-pin "D" serial connector, connect directly to the ECD with a straight-through cable (Tandy 26-117 or equivalent) with 9-pin male and female connectors. Use a 9 to 25 pin port adapter (Tandy 26-287 or equivalent) with the above cable, for those computers with a 25-pin "D" serial connector.

Set the computer communications parameters to full duplex, 1200 bits per second, 7 data bits, 1 stop bit and even parity. Apply power to the ECD, type **HE** on the keyboard and <enter> or <return>. The ECD should respond with the Serial Command Summary screen. This is the general procedure for entering any of the serial commands; type the two-character command and then type <enter>. Most commands give the user a choice of response. Type the choice in the format shown on the screen and then type <enter>. If the original choice is the correct one, then just type <enter>.

Response to commands may also be entered on the same line with the command. To do this, type the command, then either an equals sign (=) or a comma (,) and the response. For example a reference level of 3.15 feet can be entered with the **CR** (Current Reading) command as follows: CR=3.15 <enter> or CR,3.15 <enter>. This type of command is referred to as a "brief" command in the detailed command descriptions.

The ECD may be operated in the "ECD Sample", "ECD Listen" or the "Dual Sample" mode, as described in Sections 3.2, 3.3 or 3.4 below. The **SM** command determines the particular operating mode. Section 3.5 describes operation of the Test Push Button, Section 3.6 describes the Pulse Outputs and Section 3.7 describes the software commands in detail.

## 3.2 OPERATION IN THE "ECD SAMPLE" MODE

When operating in the "ECD Sample" mode, the ECD acts as the controller for a single SDI-12 sensor. In this mode, the ECD interrogates the system at a user-selected sampling interval. It is assumed that the SDI-12 sensor is set up and ready to operate.

## 4 Maintenance

---

3.2.1 Connect the computer to the ECD and use the **AS** Command to select the address of the connected SDI-12 sensor. The default address is 0 (zero).

3.2.2 Use the **MS** command to select a motor output scale of 1.0, 1.5 or 3.0 feet or 300, 375 or 750 mm per rotation of the motor shaft. Use the **DR** command to set the direction of motor rotation for an increasing input data value; the default direction is clockwise, facing the motor shaft.

3.2.3 Use the **CR** command to set the ECD reference level at or near the current reading of the SDI-12 sensor. For water level sensors, one common reference is a visual staff gage. This minimizes the running time for the ECD stepping motor to reach the position that corresponds to the input data value, at the end of a sampling interval.

3.2.4 Use the **SR** command to select a 15 second sampling interval and temporarily disconnect the computer cable. This causes the ECD to switch to SDI-12 communications mode and request an update from the connected SDI-12 sensor at the end of the 15 second interval. The stepping motor will rotate to a position that corresponds to the data value from the SDI-12 sensor.

3.2.5 Loosen the clamping screw(s) on the chart recorder input shaft and position the pen to correspond with the actual input data reading; tighten the screws. The recorder will now track the sensor data values. Reconnect the computer cable, and make any minor pen position adjustments with the **MO** command.

3.2.6 Use the **SR** command to select the desired sampling interval. The ECD updates the SDI-12 sensor at the end of the interval and each sampling interval thereafter, *after the computer cable is removed*. **CAUTION!** The 5, 15 and 30 second intervals consume significant power; the ECD does *not* enter "sleep" mode.

3.2.7 Use the **SM** Command to select the "ECD Sample" Mode of operation; type: **SM,2<enter>**. Use the **CO** command to verify all settings at this time. It is recommended that these values be recorded in the station log. Disconnect the computer cable, install fresh desiccant and close the ECD cover to place the system in operation.

## 4 Maintenance

---

### 3.3 OPERATION IN THE "ECD LISTEN" MODE

When operating in the "ECD Listen" mode, the ECD is attached to a larger SDI-12 system, and another instrument acts as the system controller. The user selects the address of the connected sensor whose output is to be recorded.

3.3.1 Connect the computer serial cable to the ECD and use the **AS** command to select the address of the connected SDI-12 sensor. The default address is 0 (zero).

3.3.2 Use the **MS** command to select a motor output scale of 1.0, 1.5 or 3.0 feet or 300, 375 or 750 mm per rotation of the motor shaft. Use the **DR** command to set the direction of motor rotation for an increasing input data value; the default direction is clockwise, facing the motor shaft.

3.3.3 Use the **CR** command to set the ECD reference level to the current reading of the associated SDI-12 Data Logger. Loosen the clamping screws on the chart recorder input shaft and position the pen to correspond with the actual input data reading; tighten the screws.

3.3.4 Use the **SM** Command to select the "ECD Listen" mode; type: **SM,1**<enter>. Use the **CO** (configuration) command to verify all settings at this time. It is recommended that these values be recorded in the station log. Disconnect the computer serial cable, install fresh desiccant and close the ChartDrive cover to place the system in operation.

3.3.5 Sampling intervals in the "ECD Listen " Mode are established by the system controller, usually an SDI-12 Data Logger. At the end of the interval, the ECD motor will rotate to a position that corresponds to the system input data reference. Use the SDI-12 Logger or the Test Push Button (Section 3.5) to request an immediate system update.

When an update has occurred, loosen the clamping screws on the chart recorder input shaft and move the pen to a position on the chart that corresponds to the input data value. Tighten the clamping screws. As an alternative, small pen position corrections may be made after an update has occurred, by *temporarily* connecting the computer cable and using the **MO** command to make small corrections without changing the input data reference. Disconnect the computer cable and close the lid when through, to return the system to normal SDI-12 operation.

## 4 Maintenance

---

### 3.4 OPERATION IN THE "DUAL SAMPLE" MODE

When operating in the "Dual Sample" Mode, the ECD is attached to a larger SDI-12 system, and another instrument acts as the system controller. However, the ECD can also act as a system controller when it is set to sample the current reading more often than the associated SDI-12 Data Logger. The sample rate may be selected, together with the recorder time scale, to give a nearly stepless chart record. However, the selection of a more frequent sample rate must be balanced against the resulting increase in power requirements.

Since two controllers will be sampling the same sensor, they must be synchronized to avoid contention. This can be done by setting up the ECD Dual Sample mode first, then programming and starting the other SDI-12 Data Logger. The ECD will begin to sample after the first sample is initiated by the Logger.

3.4.1 Connect the computer serial cable and use the **SM** Command to select the "Dual Sample Mode"; type: **SM,3**<enter>. Select the Sample Rate of the ECD using the **SR** command. Enter the sampling rate of the SDI-12 Logger as the Dual Sample Rate using the **DS** command. Generally, the sample rate of the Logger will be much less frequent than that of the ECD.

**NOTE:** If the ECD sampling rate is close to or greater than the Dual Sample Rate, the ECD will not initiate measurements, but will simply "listen" to measurements taken by the other controller and update the ECD position accordingly.

3.4.2 Use the **MS** command to select a motor output scale of 1.0, 1.5 or 3.0 feet or 300, 375, or 750 mm per rotation of the motor shaft. Use the **DR** command to set the direction of motor rotation for an increasing input data value; the default direction is clockwise, facing the motor shaft.

3.4.3 Use the **CR** command to set the ECD reference level to the current reading of the associated SDI-12 Data Logger. Loosen the clamping screws on the chart recorder input shaft and position the pen to correspond with the actual input data reading; tighten the screws.

3.4.4 Use the **CO** (configuration) command to verify all settings at this time. It is recommended that these values be recorded in the station log. Disconnect the computer serial cable, install fresh desiccant and close the ECD cover to place the system in operation.

## 4 Maintenance

---

### 3.5 OPERATION OF THE TEST PUSH BUTTON

A low-profile Test Push Button is located on the circuit board. This button is used to test the ECD motor and SDI-12 communications connection. Press the button to cause the motor shaft to rotate 0.1 foot (English) or 0.01 meter (metric) in the "up" direction. The ECD will then initiate a measurement request to the sensor connected to the SDI-12 communications channel. The received data from the sensor will then cause the motor shaft to return to the position corresponding to the current reading. This is a convenient way to mark the chart and to determine the current data value.

### 3.6 OPERATION OF THE PULSE OUTPUTS

The ECD features "up" and "down" pulse outputs, suitable as input signals for a Stevens® Telemark II, a Pulse Logger or a MultiLogger with an ML01 Digital Pulse Input Board. The outputs occur at the end of each sampling interval, with each pulse representing 0.005 feet (English) or 1 mm (metric) of water level change. Connect the signal ground (common) from signal connector pin 3 to the signal ground (common) of the Stevens Logger. Connect the "up" signal (pin 4) and the "down" signal (pin 5) to the corresponding "up" and "down" input connections on the Stevens Logger.

### 3.7 SERIAL COMMAND SUMMARY

The serial commands are accessed by a terminal or computer as described in Section 3.1. A detailed description of each command follows below.

#### 3.7.1 **AS** Command (Set SDI 12 sensor address)

The **AS** Command allows the user to set the address of an associated sensor. This command is used so the ECD knows when to accept a sensor data value. The response may be any digit from 0 through 9 or A through Y; the ECD makes no distinction between upper or lower case characters. To invoke the command, type: **AS**<enter>. The computer will respond:

AS

"Current SDI-12 SENSOR ADDRESS is 0"

"Enter new address:" 0

"New address is 0"

## 4 Maintenance

---

**\*\*BRIEF\*\***

AS,0

"New address is 0"

If there is no change, just type <enter>. Record the address.

### 3.7.2 **CO** Command (Send ECD configuration)

The **CO** command allows the user to determine the actual configuration of the ECD including current level, sample mode, sample rate, sensor address, motor scale and direction. To invoke the command, type **CO**<enter>. The computer will respond with a typical reading:

CO

```
*****CONFIGURATION REPORT*****
"
" CURRENT READING:      000.00 FT      "
"
" SAMPLE MODE:         ECD LISTEN      "
" SENSOR ADDRESS:      0                "
"
" ECD SAMPLE RATE:     15 SECONDS      "
" DUAL SAMPLE RATE:    0005 MINUTES    "
"
" MOTOR SCALING:       1.5 FT PER REVOLUTION  "
" MOTOR DIRECTION ON INCREASING LEVEL:  CLOCKWISE  "
"
*****
```

## 4 Maintenance

---

### 3.7.3 **CR Command** (Set current ECD reading)

The **CR** Command allows the user to enter a current input reading that is at or near that of the SDI-12 sensor. This only establishes the internal data reference; the motor will not run at this time. To invoke this command, type: **CR**<enter>. The computer will respond:

CR

```
"This special command, which is used primarily during initial      "
"installation, allows the ChartDrive CURENT READING to be        "
"changed. Since the default CURRENT READING is zero, connection   "
"of the ChartDrive to a sensor with a large reading would result  "
"in a significant amount of shaft rotation. This command allows   "
"the user to enter a CURRENT READING which is close to the       "
"expected sensor reading in order to reduce the amount of shaft  "
"rotation required.                                             "
```

```
"CURRENT READING is +003.00 FT"
```

```
"Enter new CURRENT READING (+/-999.99 FT):" 2
```

```
"New CURRENT READING is +002.00 FT"
```

```
**BRIEF**
```

```
CR,2
```

```
"New CURRENT READING is +002.00 FT"
```

If there is no change in the CURRENT READING, just type <enter>.

### 3.7.4 **DR Command** (Set motor direction)

The **DR** command allows the user to set the direction of motor rotation for an increasing input data value. The response may be clockwise or counter-clockwise, looking at the motor shaft. To invoke the command, type: **DR**<enter>. The computer responds:

DR

```
" The MOTOR DIRECTION setting is used to define which           "
" direction the motor shaft will rotate in response to a        "
" rising level.                                                 "
"                                                                "
" CW> CLOCKWISE                                                "
" CCW> COUNTER-CLOCKWISE                                       "
```

## 4 Maintenance

---

" Current MOTOR DIRECTION is CLOCKWISE "

"Enter desired MOTOR DIRECTION for a rising level (CW,CCW):" CW

" New MOTOR DIRECTION is CLOCKWISE "

\*\*BRIEF\*\*

DR,CW

"New MOTOR DIRECTION is CLOCKWISE"

If there is no change, just type <enter>

### 3.7.5 **DS** Command (Set Dual Sample rate)

The DS Command allows the user to set the Dual Sample rate. The response may be a value from 5 to 1440 minutes. To invoke the command, type: **DS**<enter>. The computer responds:

DS

" This command sets the DUAL SAMPLE RATE. In DUAL SAMPLE MODE " "  
" two units can sample the same sensor: the Electro ChartDrive " "  
" (ECD) and another unit (ie. a recorder). The SR command " "  
" defines the SAMPLE RATE of the ECD. This command defines " "  
" the DUAL SAMPLE RATE, which is the sample rate of the other " "  
" unit. This sample rate is usually much slower than that of " "  
" the ECD. The minimum rate allowed is 5 minutes and the " "  
" maximum is 1440 minutes. Rates which contain a fraction of a " "  
" minute should be rounded down to the nearest minute. "

" Current DUAL SAMPLE RATE is 0005 MINUTES "

" Enter new DUAL SAMPLE RATE (5 TO 1440):" 5

" New DUAL SAMPLE RATE is 0005 minutes"

\*\*BRIEF\*\*

DS,5

" New DUAL SAMPLE RATE is 0005 MINUTES"

## 4 Maintenance

---

### 3.7.6 **HE** Command (Help)

The **HE** Command allows the user to review the complete Serial Command Summary on the computer screen. To invoke the command, type:

**HE**<enter>. The computer will respond:

```
" ***** SERIAL COMMAND SUMMARY ***** "  
"  
" AS   Set SDI-12 Sensor Address      "  
" CO   Send Configuration Report     "  
" CR   Set Current Reading           "  
" DR   Set Motor Direction            "  
" DS   Set Dual Sample Rate          "  
" HE   Help                          "  
" MO   Enter Motor Offset Adjustment  "  
" MS   Set Motor Scaling              "  
" SM   Set Sample Mode               "  
" SR   Set ECD Sample Rate           "  
" SW   Send Software Revision        "  
"  
" *****"
```

### 3.7.7 **MO** Command (Enter motor offset adjustment)

The **MO** Command allows the user to make small corrections to the chart recorder pen position without affecting the input data reference. Generally, a small value will suffice. To invoke the command, type: **MO**<enter>. The computer will respond:

**MO**

```
" The MOTOR OFFSET command allows the user to instruct the "  
" Electro ChartDrive to rotate the motor shaft a certain amount. "  
" It allows the user to move the pen on the recorder without "  
" loosening hubs or pulley clamps. "
```

```
" Enter OFFSET amount (+/-99.99 FT):" -1 (-1 was entered by the user)
```

```
**BRIEF**
```

```
MO,-1
```

If no change, just type <enter>. The recorder pen will move the equivalent amount.

NOTE: English offset range is  $\pm 99.99$  ft; metric offset range is  $\pm 9.999$  m.

### 3.7.8 **MS** Command (Set motor scaling)

## 4 Maintenance

---

The **MS** Command allows the user to select a motor output scale of 1.0, 1.5 or 3.0 feet or 300, 375 or 750 mm per rotation of the output shaft. To invoke the command, type: **MS**<enter>. The computer will respond:

MS

```
" MOTOR SCALING is used to specify the number of feet (ft)  "
" or millimeters (mm) per revolution of the motor shaft    "
"                                                         "
" 1> 1.0 FT PER REVOLUTION                                "
" 2> 1.5 FT PER REVOLUTION                                "
" 3> 3.0 FT PER REVOLUTION                                "
" 4> 300 MM PER REVOLUTION                                "
" 5> 375 MM PER REVOLUTION                                "
" 6> 750 MM PER REVOLUTION                                "
```

" Current MOTOR SCALING is 300 MM PER REVOLUTION "

" Enter new MOTOR SCALING:" 5 (5 was entered by the user)

" New MOTOR SCALING is 375 MM PER REVOLUTION "

\*\*BRIEF\*\*

MS,5

" New MOTOR SCALING is 375 MM PER REVOLUTION "

## 4 Maintenance

---

### 3.7.9 **SM Command** (Set Sample Mode)

The **SM** Command allows the user to select either "ECD Listen", "ECD Sample" or "Dual Sample" modes of operation. To invoke this command, type: **SM**<enter>. The computer will respond:

SM

```
" The SAMPLE MODE defines the sampling operation of the Electro      "
" ChartDrive unit. The mode selections are:                          "
"                                                                      "
" 1> ECD LISTEN                                                       "
" 2> ECD SAMPLE                                                       "
" 3> DUAL SAMPLE                                                      "
"                                                                      "
" ECD LISTEN: The ECD will not request a reading from the           "
"   sensor. It only listens to the sensor communications and         "
"   obtains a reading when another unit requests a sensor           "
"   reading.                                                           "
" ECD SAMPLE: The ECD requests a reading from the sensor at         "
"   the rate defined by the ECD SAMPLE RATE parameter.              "
"                                                                      "
"DUAL SAMPLE: Both the ECD and another unit sample the sensor.      "
"  The ECD samples at intervals defined by the ECD SAMPLE RATE     "
"  parameter. The other unit samples at the rate defined by         "
"  the DUAL SAMPLE RATE parameter.                                    "
"                                                                      "
" Current SAMPLE MODE is ECD LISTEN "
" Enter new SAMPLE MODE:" 1
"New SAMPLE MODE is ECD LISTEN "
**BRIEF**
SM,1
"New SAMPLE MODE is ECD LISTEN "
```

## 4 Maintenance

---

### 3.7.10 **SR Command** (Set ECD sample rate)

The **SR** Command allows the user to specify the sampling rate for the ECD when it is used in the "ECD Sample" or "Dual Sample" modes. To invoke the command, type: **SR**<enter>. The computer will respond:

SR

```
" The ECD SAMPLE RATE is used to determine how often the "
" Electro ChartDrive unit should obtain a reading from      "
" the sensor.                                             "
"                                                         "
" 1> 5 SECONDS                                           "
" 2> 15 SECONDS                                          "
" 3> 30 SECONDS                                          "
" 4> 1 MINUTE                                           "
" 5> 2 MINUTES                                          "
" 6> 5 MINUTES                                          "
" 7> 15 MINUTES                                         "
" 8> 30 MINUTES                                         "
" 9> 1 HOUR                                             "
```

" Current ECD SAMPLE RATE is 15 SECONDS "

" Enter new ECD SAMPLE RATE: " 3

"New ECD SAMPLE RATE is 30 SECONDS "

\*\*BRIEF\*\*

SR,3

" New ECD SAMPLE RATE is 30 SECONDS "

### 3.7.11 **SW Command** (Send software revision)

The **SW** Command allows the user to determine the current revision of software for the ECD. To invoke the command, type: **SW**<enter>. The computer will respond with a message which may be requested when communicating with Leupold & Stevens, Inc.:

SW

" Electro Chartdrive Software - 90057 Rev X (MM/DD/YY) "

No response is required.

## 4.1 GENERAL INFORMATION

## 4 Maintenance

---

The ECD requires little periodic maintenance. Make sure the inside of the enclosure is clean and dry. Install a fresh desiccant before closing the case, for maximum protection.

### 4.2 FACTORY ASSISTANCE

If there is a problem with instrument operation, call and ask for a Stevens Customer Technical Representative. The direct dial number for Stevens is 1-800-452-5272, and the call is free from Canada or the United States of America. Many questions can be answered by telephone, or you may obtain authorization for return of the equipment, should that be necessary. The factory is open Monday through Friday from 7 a.m. to 5 p.m. in the Pacific Time Zone. If no one is available, you can leave a message at any time on an excellent phone mail system; just tell us your name, location, telephone number and how to reach you.

# 5 Troubleshooting

---

## 5.1 GENERAL INFORMATION

The ChartDrive utilizes a simple, reliable, microprocessor-based design. Most problems can be traced to basic faults like open fuses, poor signal or power connections or low voltage. The following troubleshooting table will help to guide your thinking in solving problems in the field.

## 5.2 TROUBLESHOOTING TABLE

---

SYMPTOM	PROBLEM OR ACTION
<ul style="list-style-type: none"><li>• No operation</li></ul>	<ul style="list-style-type: none"><li>• Power voltage low or missing</li><li>• Open fuse</li><li>• Signal, power or ground connection</li><li>• SDI-12 sensor or system fault</li></ul>
<ul style="list-style-type: none"><li>• Not responsive to computer commands</li></ul>	<ul style="list-style-type: none"><li>• Check cable connections</li><li>• Wrong baud rate; set computer to 1200 bits per second</li><li>• Set computer to 7 data bits, 1 stop bit, even parity</li><li>• Computer not running a terminal emulation program</li></ul>
<ul style="list-style-type: none"><li>• Double characters on computer screen</li></ul>	<ul style="list-style-type: none"><li>• Set computer to full duplex</li></ul>
<ul style="list-style-type: none"><li>• Enclosure damp inside</li></ul>	<ul style="list-style-type: none"><li>• Wipe dry; use fresh desiccant</li></ul>
<ul style="list-style-type: none"><li>• ChartDrive does not go into low-power sleep mode</li></ul>	<ul style="list-style-type: none"><li>• Disconnect computer</li><li>• Make sure that Drive is not set for 5, 15 or 30 second sampling</li></ul>

---

# 6 Technical Notes

---

## 6.1 GENERAL DESCRIPTION

The ECD is a microprocessor-based instrument which accepts input data in the standard SDI-12 format. The data is processed to provide a scaled output from a stepping motor shaft, suitable for driving a Stevens chart recorder. A serial data port provides either SDI-12 communications or selection of ECD operating parameters with a computer. The computer mode is selected whenever the EDR (external device ready) line is made active by connecting a computer at the 9 pin serial connector. All operations are performed at 1200 bits per second, 7 data bits, 1 stop bit and even parity.

## 6.2 NORMAL OPERATING MODES

During SDI-12 operation, the ECD operates in a low power "sleep" mode, waiting on a "call" from its internal timer ("ECD Sample" or "Dual Sample" modes) or from an external SDI-12 controller ("ECD Listen" mode). When the ECD receives a call, it "wakes up" and performs a data update cycle. If the ECD is in "ECD Listen" mode, it monitors the data flow and updates the output shaft position when data is transmitted by the selected sensor. When the ECD is in "ECD Sample" or "Dual Sample" modes, it "wakes up" and initiates a call to the connected SDI-12 sensor. When new input data is received, the ECD updates the output shaft position. At the end of the update cycle, the ECD returns to the low-power "sleep" mode. **CAUTION!** The ECD does *not* go into a "sleep" mode for the 5, 15 or 30 second Sample Rates, resulting in a *substantial* continuous current requirement.

## 6.3 COMMAND MODE

The ECD operates in the Command Mode when the jumper at "JP4" on the circuit board is in the position nearest the edge of the board. If a *switch* is installed in this location, the actuator will be *away from the board edge*. This is the standard factory position; see *Figure 3 ECD Component Locations*, page 8. The ECD "wakes up" when a computer is connected to the 9-pin "D" connector. The "external data ready" (EDR) line causes a "wake up" to occur and the ECD accepts serial commands as long as it is connected. When disconnected, the ECD returns to the low-power "sleep" mode and operates normally with the SDI-12 system.

## 6.4 MONITOR MODE

When the jumper at "JP4" is moved to the position away from the edge (*or switch towards the edge*) of the circuit board, the ECD operates in the Monitor Mode. All activity on the SDI-12 bus may be monitored on the screen of a computer connected to the 9-pin Serial Port Connector, but the ECD will *not* accept any serial commands from the computer. Move the jumper by

## 6 Technical Notes

---

grasping the body with your fingers or long-nose pliers; lift the body straight up and reposition it over the pair of pins closer to the center of the circuit board. To return to Command Mode, position the jumper body over the outer pair of pins. If a *switch* is in the JP4 location, move it to the *opposite* relative position from that stated for the jumper.

### 6.5 SDI-12 TRANSPARENT MODE

The ECD supports the Transparent Mode as required of SDI-12 data recorders and described in SDI-12 specification Version 1.0 (11/30/93 revision), Section 4.4.8.1. A computer or terminal may be connected to the ECD serial port 9-pin "D" connector and used to issue commands or monitor traffic on the SDI-12 bus. The transparent mode has the following characteristics:

1. the ECD buffers a command string received from a computer or terminal until it receives the ! character;
2. the ECD wakes the sensor with a break; then it sends the buffered command to the sensor, using the SDI-12 protocol;
3. the ECD receives the response from the sensor and transmits the response to the computer or terminal.

It is recommended that commands not be issued in this mode when there is another SDI-12 controller or data logger connected to the SDI-12 bus, to avoid contention. There is normally just one master controller on the SDI-12 bus.

### 6.6 INITIAL CONDITIONS

When shipped, the following initial conditions (default values) apply:

- Baud Rate = 1200 bits/second
- SDI-12 sensor address (AS) = 0
- Motor Direction (DR) = clockwise (CW), facing the motor shaft
- Dual Sample Rate (DS) = 15 minutes
- Motor Offset (MO) = 0
- Motor Scale (MS) = 1.5 feet per revolution
- Sample Mode (SM) = ECD Listen
- Sample Rate (SR) = 1 minute
- Software revision (SW) = current level at time of shipment
- Jumper JP4 towards the outer edge of the board