

**Position Analog
Transmitter**
INSTRUCTION 45560
MARCH 1999

Table of Contents

1 INTRODUCTION	1
1.1 GENERAL DESCRIPTION	1
1.2 SAFETY INFORMATION	3
1.3 PRINCIPLES OF OPERATION	3
1.4 POSITION ANALOG TRANSMITTER SPECIFICATIONS	4
2 INSTALLATION	6
2.1 EQUIPMENT AND TOOLS REQUIRED	6
2.2 MECHANICAL INSTALLATION	6
2.2.1 Unpacking the PAT	6
2.2.2 Installing the Float Pulley	7
2.2.3 Positioning the PAT	7
2.2.4 Mounting the PAT	8
2.3 ELECTRICAL INSTALLATION	8
2.3.1 Configuring the PAT with a Stevens Instrument	9
2.3.2 Configuring the PAT with Receivers Having an Internal Loop Supply	9
2.3.3 Configuring the PAT with a Receiver and External Power Supply	10
2.3.4 Configuring the PAT with a 1 to 5 VDC Receiver	11
2.3.5 Configuring the PAT With a 0.2 to 1 VDC Receiver	12
2.4 INSTALLATION CHECKOUT	12
3 MAINTENANCE AND TROUBLESHOOTING	14
3.1 MAINTENANCE	14
3.2 TROUBLESHOOTING	14
3.3 TROUBLESHOOTING CHART	15
4 TECHNICAL NOTES	17
4.1 GENERAL	17
4.2 MECHANICAL STOP	17
4.3 CHECKING AND ADJUSTING THE MECHANICAL STOP ON MODELS 1 AND 2	17
4.4 ZERO AND SPAN ADJUSTMENTS	18

Table of Contents

ILLUSTRATIONS

Figure 1 Stevens Position Analog Transmitter	1
Figure 2 Position Analog Transmitter Dimensions	2
Figure 3 System Schematic, Receiver With Internal Loop Supply	9
Figure 4 Receiver Voltage vs Loop Resistance	10
Figure 5 System Schematic With External Loop Supply	11
Figure 6 System Schematic with 1-5 VDC Receiver	11
Figure 7 System Schematic with 0.2 - 1 VDC Receiver	12

TABLES

Table 1 PAT Models versus Range	3
Table 2 PAT Characteristics	17

Safety and Equipment Protection

WARNING!

ELECTRICAL POWER CAN RESULT IN DEATH, PERSONAL INJURY OR CAN CAUSE DAMAGE TO EQUIPMENT.

If the instrument is driven by an external power source, disconnect the instrument from that power source before attempting any repairs.

WARNING!

BATTERIES ARE DANGEROUS. IF HANDLED IMPROPERLY, THEY CAN RESULT IN DEATH, PERSONAL INJURY OR CAN CAUSE DAMAGE TO EQUIPMENT.

Batteries can be hazardous when misused, mishandled, or disposed of improperly. Batteries contain potential energy, even when partially discharged.

WARNING!

ELECTRICAL SHOCK CAN RESULT IN DEATH OR PERSONAL INJURY.

Use extreme caution when handling cables, connectors, or terminals; they may yield hazardous currents if inadvertently brought into contact with conductive materials, including water and the human body.

CAUTION!

Be aware of protective measures against environmentally caused electric current surges.

In addition to the previous warnings and cautions, the following safety activities should be carefully observed.

Children, Adolescents

Safety and Equipment Protection

NEVER give batteries to young people who may not be aware of the hazards associated with batteries and their improper use or disposal.

Jewelry, Watches, Metal Tags

To avoid severe burns, NEVER wear rings, necklaces, metal watch bands, bracelets, or metal identification tags near exposed battery terminals.

Heat, Fire

NEVER dispose of batteries in fire or locate them in excessively heated spaces. Observe the temperature limit listed in the instrument specifications.

Charging

NEVER charge "dry" cells or lithium batteries that are not designed to be charged.

NEVER charge rechargeable batteries at currents higher than recommended ratings.

NEVER recharge a frozen battery. Thaw it completely at room temperature before connecting charger.

Unvented Container

NEVER store or charge batteries in a gas-tight container. Doing so may lead to pressure buildup and explosive concentrations of hydrogen.

Short Circuits

NEVER short circuit batteries. High current flow may cause internal battery heating and/or explosion.

Damaged Batteries

Personal injury may result from contact with hazardous materials from a damaged or open battery. NEVER attempt to open a battery

Safety and Equipment Protection

enclosure. Wear appropriate protective clothing, and handle damaged batteries carefully.

Disposal

ALWAYS dispose of batteries in a responsible manner. Observe all applicable federal, state, and local regulations for disposal of the specific type of battery involved.

NOTICE

Stevens makes no claims as to the immunity of its equipment against lightning strikes, either direct or nearby.

The following statement is required by the Federal Communications Commission:

WARNING - This equipment generates, uses, and can radiate radio frequency energy and, if not installed in accordance with the instructions manual, may cause interference to radio communications. It has been tested and found to comply with the limits for a Class A computing device pursuant to Subpart J of Part 15 of FCC Rules, which are designed to provide reasonable protection against such interference when operated in a commercial environment. Operation of this equipment in a residential area is likely to cause interference in which case the user at his own expense will be required to take whatever measures may be required to correct the interference.

USER INFORMATION

Stevens makes no warranty as to the information furnished in these instructions and the reader assumes all risk in the use thereof. No liability is assumed for damages resulting from the use of these instructions. We reserve the right to make changes to products and/or publications without prior notice.

Safety and Equipment Protection

Blank Page...

1 Introduction

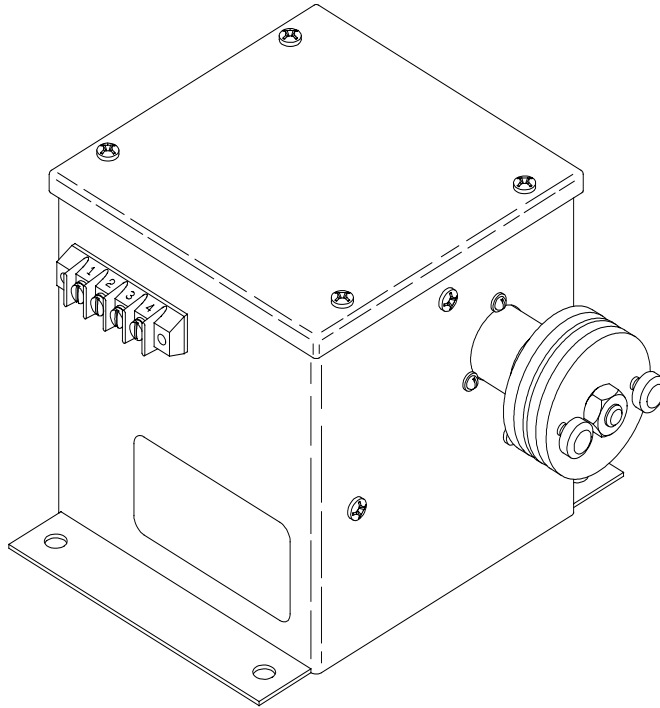

Figure 1 Stevens Position Analog Transmitter

1.1 GENERAL DESCRIPTION

The Position Analog Transmitter (PAT) is a 4-20 milliamper (mA) transmitter which has a float pulley input and can provide several types of output, depending on external connections. The PAT (see *Figure 1*) was designed primarily as a 4-20 mA input device for the AxSys MPU and the Stevens Model 1511 Position Monitor. However, having a standard 4-20 mA output makes the PAT usable as an input device for other receivers. The PAT is also capable of 0.2 to 1 VDC and 1 to 5 VDC output, depending on the connections made at the external barrier strip.

1 Introduction

When operated with Stevens instruments, the PAT obtains its power from the receiving device. When the PAT is operated as a stand-alone transmitter, the user must provide DC power. The PAT is housed in an aluminum enclosure (for dimensions, see *Figure 2*). The cover may be removed to provide access to the span and zero adjustment potentiometers, as well as the gears for major range changes.

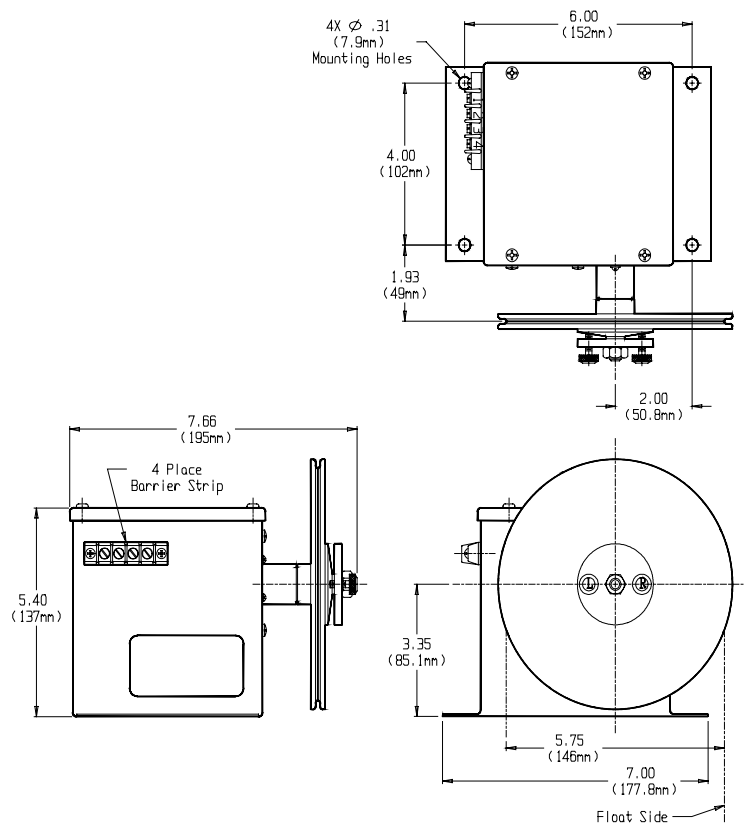

Figure 2 Position Analog Transmitter Dimensions
(shown with optional 18 inch pulley)

1 Introduction

The PAT is available in seven models, with the following range choices:

MODEL	MAXIMUM HEAD (1)	ADJUSTABLE RANGE
1	0.8 feet (0.2 m)	0-0.2 to 0-0.8 feet/0.05 to 0.2 m
2	2.5 feet (0.6 m)	0-0.8 to 0-2.5 feet/0.2 to 0.6 m
3	10 feet (2.6 m)	0-2.5 to 0-10 feet/0.65 to 2.6 m
4	18 feet (4.6 m)	0-10 to 0-18 feet/2.6 to 4.6 m
5	32 feet (8.1 m)	0-18 to 0-32 feet/4.6 to 8.1 m
6	58 feet (14.5 m)	0-32 to 0-58 feet/8 to 14.5 m
7	105 feet (26 m)	0-58 to 0-105 feet/14.5 to 26 m

NOTES: (1) English ranges with 18 inch and metric ranges with 375 mm circumference float pulleys

Table 1 PAT Models versus Range

Please refer to *Section 4 Technical Notes* for additional information on gearing, potentiometers, types of stops and recommended float sizes.

1.2 SAFETY INFORMATION

Before performing any procedures in this manual, please read all applicable warnings and cautions.

1.3 PRINCIPLES OF OPERATION

The PAT is basically a 4-20 mA transmitter. A standard 4-20 mA signal circuit consists of two wires connecting the transmitter at one end and the receiver at the other end. Somewhere in this series loop there is a DC voltage source. Sometimes it is built into the receiver (as in Stevens instruments), sometimes it is a separate power supply and sometimes it is built into the transmitter. Transmitters which are powered by AC and convert this to DC to the signal loop are called four-wire transmitters; the PAT is a two-wire transmitter.

The amount of direct current in the loop is controlled by the PAT and represents the water level information being transmitted. The current values correspond linearly with the head levels; there is a 4 mA offset at the start. Thus 4 mA is the minimum current and represents the bottom of the operating range. Conversely, 20 mA is the design maximum and represents the top of the operating range. Because the current is linear, a simple calculation shows that 12 mA represents the middle of the operating range. Currents less than 4 mA or more than 20 mA indicate an adjustment or circuit problem.

1 Introduction

Generally speaking, 4-20 mA systems have the following advantages:

- It is easy to detect a break in the signal circuit because transmitted "zero" is 4 mA, not zero current.
- The DC signal is less affected by induced noise than an AC signal.
- Resistance changes in the loop (within limits) do not degrade the information being transmitted, since it is the current that is being controlled.

Rotation of the PAT's input shaft is coupled to the shaft of a precision potentiometer through a pair of gears. A choice of gears and potentiometers determines the available ranges (refer to *Table 2, Section 4*). The potentiometer output connects to an integrated circuit which controls the current in the signal loop.

In addition to being a 4-20 mA transmitter, the PAT also has voltage output capabilities. When operating in the voltage mode, the 4-20 mA current passes through either a 50 ohm resistor to generate 0.2 to 1 VDC or through a 250 ohm resistor to develop a 1 to 5 VDC output. These resistors are mounted on the PAT's internal circuit board, and are activated when terminal 2 or 3 of the exterior terminal strip is used.

1.4 POSITION ANALOG TRANSMITTER SPECIFICATIONS

Input: Shaft and pulley clamp to accept standard Stevens 18 inch or 375 mm circumference float pulley.

Output: 4-20 mA, 0.2 to 1 VDC or 1 to 5 VDC as selected on external terminal strip.

Range: Determined by internal selection of gears and potentiometers (see *Table 2*).

Torque: Models 1, 2 and 3: 0.3 ounce-inch or less. Models 4 through 7: 0.6 ounce-inch or less.

Accuracy: Thermal error less than 0.05%/°C. Other errors (not including float lag and line shift errors) are less than 0.75% for Models 2 and 3 and less than 0.38% for the other four models. Accuracy calculations are based on the maximum head for any range in the adjustment band.

Power requirements: Supplied by connected Stevens instrument. When receiver type is 4-20 mA, 12.4 to 40 VDC must be supplied by the receiver, or a power supply in series with the receiver. When the receiver type is 0.2-1 VDC, 13.4 to 40.2 VDC must be supplied by a power supply. When the

1 Introduction

receiver type is 1-5 VDC, 17.4 to 41 VDC must be supplied by a power supply. The voltage supplied to the transmitter must be within these ranges, after taking loop circuit resistance into account.

Operating temperature: -40 to +70 °C (-40 to 158 °F)

Humidity: To 95% relative, non-condensing. This can be improved by installing fresh desiccant inside the enclosure.

Size: 5.4 by 7 by 7.66 in (137 by 178 by 195 mm) including mounting flanges and input shaft (see *Figure 2*).

Weight: 2 lb (0.91 kg).

2 Installation

2.1 EQUIPMENT AND TOOLS REQUIRED

The following equipment and tools are required to install the PAT:

1. Float, float pulley, float line, counterweight and end hooks.
2. Four 1/4 inch (6 mm) mounting screws (or bolts and nuts) of suitable length to fasten the PAT to the mounting platform.
3. Guide pulley if required and its mounting hardware.
4. Two large "C" clamps (three if guide pulley is required) for temporarily clamping the system in position to check the float clearance.
5. Drill and drill bits of suitable size for mounting hardware.
6. Screwdriver and/or wrenches for tightening mounting hardware.
7. An assortment of screwdrivers (flat blade and Phillips) for terminal strip, end hooks, trim potentiometers and PAT cover screws.
8. Combination pliers or other durable cutting tool for cutting float line and bending end hooks.
9. Terminal lugs, crimping tool and pocket knife (or wire stripper) for stripping wires.
10. Milliammeter or voltmeter for checking PAT's output.
11. Allen wrenches for adjusting mechanical stop and for gearing changes, if required.

2.2 MECHANICAL INSTALLATION

Perform the following procedures to install the PAT.

2.2.1 Unpacking the PAT

- a. Remove the PAT from its packing material; several parts and accessories are individually wrapped.
- b. Check the packing list to ensure that *all* items are accounted for *before* discarding packing material.
- c. Inspect for any apparent shipping damage and inform the shipping agency *immediately* if any is found.

2 Installation

2.2.2 Installing the float pulley

- a. Place the pulley on the shaft with the recessed side of the pulley towards the PAT.
- b. Installed the cupped washers with the recessed side towards the pulley.
- c. Thread the clamping disc (with Left and Right-hand clamping screws) onto the shaft.
- d. Thread the 5/16-24 hex nut onto the shaft. Tighten the hex nut against the clamping disc to prevent accidental loosening.
- e. Tighten the Left and Right-hand clamping screws against the cup washer.

2.2.3 Positioning the PAT

- a. Place the PAT on a firm support or shelf over the float well.
- b. Temporarily clamp the unit in position with "C" clamps. Facing the shaft, the float should be on the right side of the pulley, the counter-weight should be on the left. This will cause the pulley to rotate counterclockwise as the float rises.

CAUTION!! Do not allow the float or counterweight to fall unchecked or manually spin the float pulley until the stop is hit. Failure to observe this caution can result in damage to the potentiometer, stop, gears or zero adjustment due to the pulley's rotational inertia.

- c. Position the PAT so that the float and counterweight will not touch the sides of the float well or interfere with each other throughout their range of operation (use guide pulleys, if necessary). If there is any doubt about clearance, the float, line, and counterweight should be temporarily installed and operated through the full range.
- d. Attach the float line to the float and counterweight, using the two adjustable hooks provided.
- e. Adjust the float line length so the counterweight does not touch bottom when the float is at the high point of the operating range.
- f. Verify that the line is long enough to prevent the counterweight from running into the pulley or support shelf when the float is at the bottom of its operating range.

2 Installation

g. If necessary, extra float tape may be broken off by sharply bending it. Beaded float cable should be cut 1/4 inch (6 mm) beyond a bead to prevent raveling. If unbeaded cable is cut, anneal the area by heating to a red heat to reduce raveling.

2.2.4 Mounting the PAT

- a. Remove the float, line and counterweight (if temporarily installed).
- b. Using a pen or pencil, mark the location of the four mounting flange holes on the instrument shelf.
- c. Remove the PAT and drill the support shelf for the mounting hardware.
- d. Reinstall the PAT using the hardware.
- e. If a guide pulley is required, drill the support shelf and mount the pulley.
- f. Install the float, float line and counterweight and recheck that the float and counterweight pass each other freely and do not touch the sides of the float well. Make sure that the float line beads of float tape holes engage the corresponding features on the float pulley.

2.3 ELECTRICAL INSTALLATION

WARNING!! When installing electrical equipment, make certain that the electrical power is removed for safety of personnel.

The PAT can provide several types of output, depending on external connections. Determine the type of operation (see *Section 2.3.1* through *2.3.4*). Make connections as shown.

Temporarily install a milliammeter or voltmeter, depending on the PAT application. If an adjustment is required, it can be determined whether it needs to be done at the transmitter or receiver.

2 Installation

2.3.1 Configuring the PAT With a Stevens Instrument

When operating the PAT with a Stevens instrument, the PAT derives its power from that instrument's 24 VDC loop supply. The PAT controls the current in the loop (4-20 mA) in relation to the position of its float pulley shaft. Connections are shown in *Figure 3*.

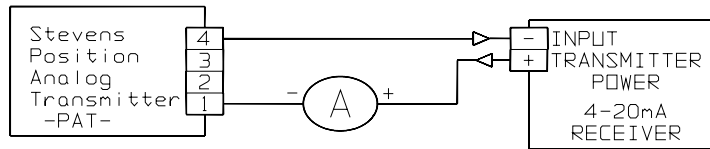

Figure 3 System Schematic - Receiver with Internal Loop Supply

When the PAT is operating properly, the span potentiometer is adjusted so that the 20 mA output coincides with the maximum head to be transmitted. Conversely, the PAT's zero potentiometer must be set so that the output is 4 mA when the PAT is at zero (minimum head - please refer *Section 4.4*).

2.3.2 Configuring the PAT with Receivers Having an Internal Power Supply

Many receivers have internal power supplies to provide power for the 4-20 mA loop. Connections for these units are the same as for a Stevens instrument (see *Figure 3*). Make connections at the receiver according to the receiver's instructions.

For this application, the voltage applied to the terminals of the PAT should be between 12.4 and 40 VDC. The acceptable voltage output of the receiver is dependent on the the resistance of the 4-20 mA loop. Voltage can be determined by referring to the graph in *Figure 4*.

In *Figure 4*, note that the maximum voltage/resistance combination is 46.9 VDC at 1725 ohms. At 1000 ohms, the acceptable receiver output voltage is 32.4 to 44 volts. At 100 ohms, the acceptable range is 14.4 to 40.4 VDC.

When the PAT is operating properly, the span potentiometer is adjusted so that the 20 mA output coincides with the maximum head to be transmitted. Conversely, the PAT's zero potentiometer must be set so that the output is 4 mA when the PAT is at zero (minimum head) - please refer to *Section 4.4*.

2 Installation

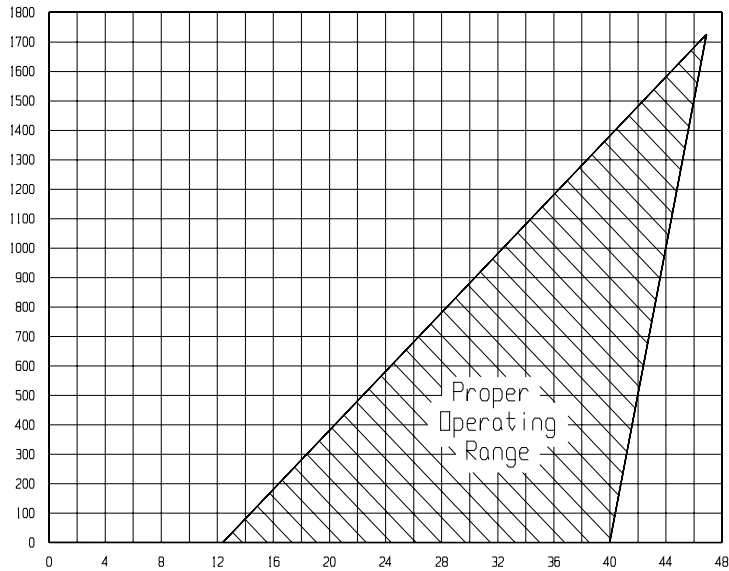

Figure 4 Receiver Voltage vs Loop Resistance

2.3.3 Configuring the PAT with a Receiver and External Power Supply

Some receivers do not supply the voltage for the 4-20 mA loop. For these applications, an external power supply will be required. Voltage selection is the same as for receivers with an internal power supply. Refer to *Figure 5* for proper connections.

When the PAT is operating properly, the span potentiometer is adjusted so that the 20 mA output coincides with the maximum head to be transmitted. Conversely, the PAT's zero potentiometer must be set so that the output is 4 mA when the PAT is at zero (minimum head) - please refer to *Section 4.4*.

2 Installation

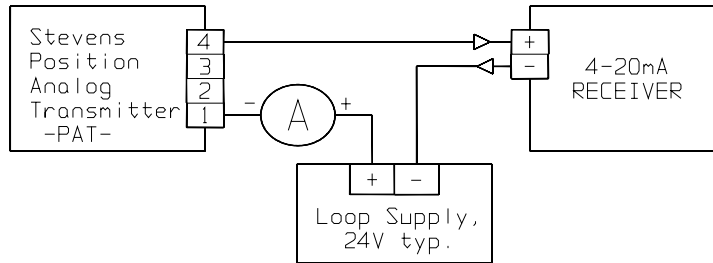

Figure 5 System Schematic with External Loop Supply

2.3.4 Configuring the PAT with a 1-5 VDC Receiver

This type of configuration is shown in Figure 6. The power supply must be capable of supplying 20 mA at a voltage between 17.4 and 41 VDC. The input resistance of the receiver should be greater than 25,000 ohms in order to keep the circuit loading effects to less than 1%. A much higher value of input resistance is preferred, to minimize the affect of changing temperature on signal line resistance.

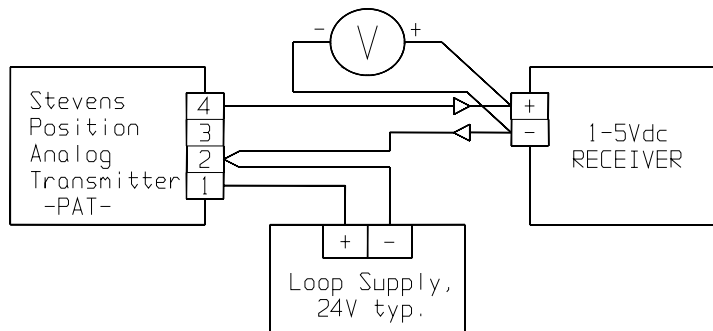

Figure 6 System Schematic with 1 - 5 VDC Receiver

2 Installation

2.3.5 Configuring the PAT with a 0.2 - 1 VDC Receiver

The PAT may also be configured with 0.2-1 VDC receiver (see *Figure 7*). The power supply must be capable of supplying 20 mA at a voltage between 13.4 and 40.2 VDC. The input resistance should be greater than 5,000 ohms to keep circuit loading effects to less than 1%. For lower resistance loads, the loading effects can be improved by adjusting span and zero with the load connected. (please refer to *Section 4.4*).

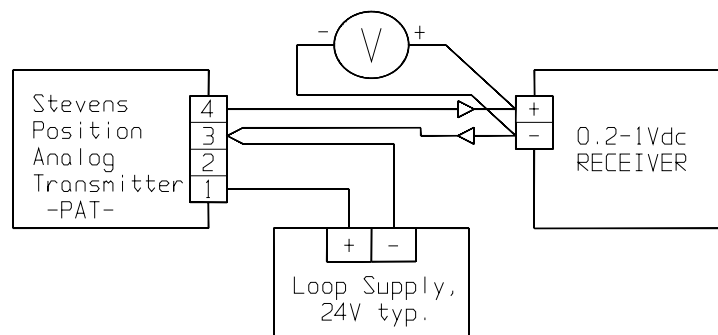

Figure 7 System Schematic with 0.2 - 1 VDC Receiver

2.4 INSTALLATION CHECKOUT

Perform the following steps to verify system operation:

2.4.1. Apply power to the system.

2.4.2 Observe the reading of the receiver. Position the float to zero and check that the current is 4 mA (1.0 or 0.2 V), and that the receiver responds accordingly.

2.4.3. If the output of the PAT is not correct, or if you believe it has not been set, refer to *Section 4 Technical Notes*, and make zero and span adjustments.

2.4.4. If the PAT's output is correct, but the receiver's response is incorrect, make adjustments to the receiver as required; refer to the receiver's instruction manual.

2 Installation

2.4.5. After all adjustments have been made, turn off system power and remove the milliammeter or voltmeter. Re-connect the signal loop broken by removal of the milliammeter.

2.4.6. Replace the PAT cover, if open.

2.4.7. Re-apply system power.

3 Maintenance and Troubleshooting

3.1 MAINTENANCE

There is no periodic maintenance, but observe the following precautions:

3.1.1 Ensure that any connected power supply is maintaining its rated output, and connections are tight.

3.1.2 Avoid entry of moisture into the enclosure, if the top is removed.

3.1.3 Ensure that there are no restrictions on moving parts, such as a float, line, float pulley, float or counterweight.

3.2 TROUBLESHOOTING

The following is a guide to troubleshooting various operational problems with the PAT. These are things that should be checked before contacting the factory for assistance. If you cannot solve the problem in the field, call and ask for a Stevens Customer Technical Representative. The direct dial number for Stevens is 1-800-452-5272, and the call is free from Canada or the U.S.A. An alternative number is 503 469-8000.

Please provide an instrument description and serial number, when possible. Many questions can be answered by telephone, or you may obtain an authorization for return of the equipment, should that be necessary. The factory is open Monday through Friday from 7 a.m. to 5 p.m., in the Pacific Time Zone. If no one is available, you can leave a message at *any* time on an excellent phone mail system; just clearly tell us your name, location, telephone number and how to reach you.

TROUBLESHOOTING CHART (next page)

3 Maintenance and Troubleshooting

3.3 TROUBLESHOOTING CHART (below):

SYMPTOM	CAUSE/CORRECTIVE ACTION
No response at the receiver	<ol style="list-style-type: none"> 1. Check receiver and power supply fuses. 2. Check that DC voltage is correctly applied at the PAT (a diode protects from reverse polarity). <ol style="list-style-type: none"> a. If used with Stevens instrument, check for approximately 24 VDC at the PAT. b. If receiver input is 4-20 mA, same as above. c. If receiver input is 1-5 VDC, check that voltage at PAT is 17.4 to 41 VDC. Also check that PAT output signal is being applied to receiver input. d. If receiver input is 0.2-1 VDC, check that voltage at PAT is 13.4 to 40.2 VDC. Also check that PAT output signal is being applied to receiver input. 3. PAT has voltage applied but no current (or voltage) output. Check for wrong polarity or circuit board failure. Remove cover and visually inspect board for visual failure or loose connections. 4. PAT has voltage applied but only 3.2 mA (0.8 or 0.16 volts) regardless of pulley position. The sensing potentiometer is faulty or has a poor connection. Inspect and correct.
Receiver registers full scale, no matter what the pulley position	<ol style="list-style-type: none"> 1. Signal current (or voltage) exceeds normal values due to incorrect PAT connections. See Section 2.3 and correct. 2. Signal current at receiver exceeds normal value because wiring between units contains short circuit or leakage. Inspect and correct.
Receiver's response is erratic, not correct or shifts with time.	<ol style="list-style-type: none"> 1. Determine whether problem is with PAT or receiver. Install meter as shown in applicable diagram in Section 2.3. Check that receiver follows PAT signal. 2. PAT output is not correct for water level change: <ol style="list-style-type: none"> a. Gearing not correct for desired range (<i>Section 4 Technical Notes</i>). b. Input drive sprocket ratio not correct. c. Span/zero setting not correct (<i>Section 4.4</i>). d. The mechanical stop has slipped. Reset the stop and re-adjust zero and span (<i>Section 4.4</i>). e. Gear setscrew is loose. Remove power and re-tighten the setscrew. Check zero and span adjustment (<i>Section 4.4</i>). 3. Float line has disengaged from pulley, pulley has slipped

3 Maintenance and Troubleshooting

	<p>or float has taken on water (sinking).</p> <ol style="list-style-type: none">a. Inspect that cable beads/tape holes engage their correct pulley recesses/splines.b. Determine whether problem is with float, line or PAT calibration. Temporarily remove float line from pulley and rotate pulley while checking that receiver follows accordingly. If response seems normal, re-install float line. Operate the float system through the entire range while watching for interference or other problems. Loosen pulley and re-zero the PAT using a known output that corresponds to a known water level. Re-tighten the pulley (using <u>L</u>eft- and <u>R</u>ight-hand clamping screws).c. If float is taking on water, repair or replace it. <p>4. The system works at lower end of range, but cannot handle the upper end. Verify if line resistance is too high or if voltage supply is low (<i>Section 2.3</i>).</p> <p>5. The PAT runs into the mechanical stop before upper end of range is reached:</p> <ol style="list-style-type: none">a. Mechanical stop has slipped (<i>Section 4.2</i>).b. Gearing selection or placement is not consistent with range (<i>Section 4 Technical Notes</i>). <p>6. Output current is erratic with changes in pulley position. If the output drops suddenly to 3.2 mA (0.8 or 0.16 V), it indicates that the potentiometer is not making contact. This can happen at either end of the resistance range, if the stop is out of adjustment or, on Model 3, when zero is exceeded. A similar response occurring in the middle of the resistance range probably indicates a worn or dirty spot in the potentiometer. Replace the potentiometer.</p>
--	---

4 Technical Notes

4.1 GENERAL

Please refer to Table 2 for Position Analog Transmitter (PAT) characteristics.

MODEL	GEARS, TEETH	ZERO STOP	POT. TYPE	ROTA-TION	FLOAT SIZE (1)
1	72:42	Yes	P (2)	350°	8 inch
2	42:72	Yes	P	350°	8 inch
3	14:100	No	P	350°	5 inch
4	51:63	Yes	W (3)	10 turn	5 inch
5	36:78	Yes	W	10 turn	5 inch
6	23:91	Yes	W	10 turn	4 inch
7	14:100	Yes	W	10 turn	4 inch

NOTES: (1) Minimum recommended float diameter
(2) Conductive plastic resistance element
(3) Wirewound resistance element

Table 2 PAT Characteristics

4.2 MECHANICAL STOP

A mechanical stop assists in locating "zero" at installation. In Model 4 through 7, this stop is built into the potentiometer, and is non-adjustable. In Models 1 and 2, an adjustable stop is mounted on the potentiometer's shaft. Model 3 does not have a stop. Model 3's gear ratio and large float generate more torque than the stop can safely withstand. The same gear ratio is used in Model 7, but the float is smaller. Limit input torque to 105 ounce-inch.

CAUTION!! Do not allow the float or counterweight to fall unchecked or manually spin the float pulley until the stop is hit. Failure to observe this caution can result in damage to the potentiometer, stop, gears or zero adjustment due to the pulley's rotational inertia.

4.3 CHECKING AND ADJUSTING THE MECHANICAL STOP ON MODELS 1 AND 2

To check and adjust the stop on Models 1 and 2, wire the system and temporarily install a milliammeter or voltmeter as shown in *Section 2.3*. Apply power and observe the current (voltage) reading as the float pulley is rotated clockwise and the mechanical stop is approached. The current (voltage) should decrease to 4 mA (1.0 or 0.2 V). Small differences can be adjusted with the zero potentiometer (*Section 4.4*), but larger differences

4 Technical Notes

require stop adjustment. If the current (voltage) *suddenly* drops to 3.2 mA (0.8 or 0.16 V), it means that the potentiometer's slider has passed the end of the resistance element, and the stops needs to be adjusted.

NOTE: Do not adjust the stop to coincide with the exact end of the resistance element; the "ragged" end can introduce errors.

Remove the PAT's cover and locate the adjustable stop on the potentiometer shaft. Loosen the stop's clamp screw and re-position the stop. Tighten the clamp screw and check that the adjustable stop does not rub on the potentiometer mounting plate; rotate the adjustable stop through a complete revolution while checking.

4.4 ZERO AND SPAN ADJUSTMENTS

Two small trim potentiometers are mounted on the PAT's circuit board. The one marked *zero* makes small changes to the output when the PAT is at the lower end of its operating range. The one marked *span* makes large changes to the output when the PAT is at the upper end of the operating range.

When the PAT is purchased, it is set to the range requested on the Sales Order or the full range specified by the model number.

To set the potentiometers, perform the following:

1. As indicated in *Section 2.3*, wire the system and temporarily install a milliammeter or voltmeter.
2. Apply power and rotate the float pulley clockwise to the zero stop (Model 3 has no mechanical stop, so the end of the potentiometer's resistance element must be sensed as described in *Section 4.3*).
3. Remove the PAT cover and adjust the *zero* potentiometer for an output of 4 mA (1.0 or 0.2 V).
4. There are several ways to set the *span* potentiometer. The method suggested here requires "zeroing" the float and float line system and using it to position the PAT to the top of the operating range.
5. Check that the PAT is at zero (against the zero stop) when the float's flotation point is also at zero (bottom of the operating range). Adjust as necessary using Left- and Right-hand float pulley clamping screws.
6. Raise the float until its flotation point is at the top of the operating range.
7. Adjust the *span* potentiometer for 20 mA (5.0 or 1.0 V) output signal.

4 Technical Notes

8. Because there is a slight interaction between *span* and *zero* adjustments, it is good practice to go back and check *zero*. If *zero* needs any fine tuning, be sure to go back and re-check the *span* adjustment.

9. After all adjustments have been made, turn off system power and remove the milliammeter or voltmeter. Re-connect the signal loop broken by the removal of the milliammeter or voltmeter.

10 Replace the PAT cover, and re-apply system power.