

Pressure Sensor

PS700

Version 1.02

*User
Manual*



+61 7 4660 1888
Greenspan Customer Service

Technical Support when you need it

The correct choice of sensor should be supported by professional advice to ensure long term success in the field. **Greenspan Technical Services** is dedicated to customer support and provides assistance in the selection, installation, deployment and commissioning of sensors with a full range of consulting services.

A full technical support and field advice service can be accessed by ringing **Customer Service** on +61 7 4660 1888 between 8am - 6pm, 5 days a week.

All requests for information will be serviced within 24 hours.

All Greenspan products are designed, developed and manufactured in Australia and can be supplied at short notice.

Warranty Details

Greenspan warrants all new Greenspan products against defects in materials and workmanship for **12 months** from the date of invoice. During the warranty period, we will repair or, at our option, replace at no charge a product that proves to be defective provided that it is returned, shipping prepaid, to Greenspan Technology Pty Ltd. Greenspan's liability and obligations in connection with any defects in materials and workmanship are expressly limited to repair or replacement, and the sole and exclusive remedy in the event of such defects shall be repair or replacement. Greenspan's obligations under this warranty are conditional upon it receiving prompt written notice of claimed defects within the warranty period and its obligations are expressly limited to repair or replacement.

This warranty does not apply to products or parts thereof which have been altered or repaired outside of the Greenspan factory or other authorised service centre, or products damaged by improper installation or application, or subjected to misuse, abuse neglect or accident. This warranty also excludes items such as reference electrodes and Dissolved Oxygen membranes that may degrade during normal use.

Greenspan Technology Pty Ltd will not be liable for any incidental or consequential damage or expense incurred by the user due to partial or incomplete inoperability of its products for any reason whatsoever or due to inaccurate information generated by its products.

All Warranty service will be completed as soon possible. If delays are unavoidable customers will be contacted immediately.

The sensors should not be dismantled unless under instruction from Greenspan. Incorrect handling will void the warranty.

Contents

1	INTRODUCTION	
	Overview.....	1
2	PRESSURE MEASUREMENT	
	Background.....	2
	Techniques for Measuring Pressure.....	2
	Specific Characteristics of Pressure and Depth.....	2
	Water Density and Gravity.....	3
3	THE HARDWARE	
	Sensor Design.....	4
	Transducer.....	4
	Signal Conditioning Circuit.....	4
	Data Cable and Vent Tube.....	5
	Protection.....	5
	Pressure Venting System.....	6
4	SENSOR MANUFACTURE	
	Quality Control Procedures.....	8
5	INSTALLATION	
	Connection.....	9
	Field Installation Instructions.....	10
	Option 1: Non Turbulent Conditions.....	10
	Option 1: High Turbulent Conditions.....	10
	Atmospheric Venting of Depth Sensors.....	11
	Sensor Nose Cones.....	11
	Other Considerations.....	11
6	CLEANING AND MAINTENANCE	12
7	TROUBLESHOOTING	13
8	APPENDIX	
	PS700 Specification.....	14
	PS700 Certificate of Conformance (Example Only).....	15

INTRODUCTION

Overview

The GREENSPAN Pressure Sensor, model number PS700 is a pressure sensor designed for two wire connection.

The instrument is packaged in a small, robust, stainless steel housing fully sealed against moisture penetration and is hardwired to either vented or non vented cable supplied by Greenspan.

The transducer is a capacitive ceramic pressure sensitive diaphragm. Its special features include high overload protection (up to 60 times nominal pressure) corrosion resistance and long term stability.

The changes in the capacitive element varies with applied pressure. This variation is measured by an electronic circuit and converted into a current ranging from 4mA at zero pressure to 20mA at full scale. The sensor can be supplied in a variety of standard ranges.



PS700 Pressure Sensor

PRESSURE MEASUREMENT

Background

There are traditionally numerous ways to monitor depth readings of water bodies and they vary from floats and pulleys attached to chart recorders, capacitance tubes, acoustic reflection devices and pressure sensors attached to data loggers. The choices are dependent upon cost, accuracy and physical limitations of the measurement system devices and environmental constraints.

Techniques for Measuring Pressure

Several technologies have evolved in recent years to measure pressure in fluids. They include simple strain gauge silicon or stainless steel diaphragm sensors to more sophisticated capacitance ceramic and resonant quartz sensors. There has been a similar evolution with the electronic circuits that monitor the physical change of the sensing technology. These include basic in-sensor temperature compensation or more sophisticated microprocessor controlled techniques which manage both temperature compensation and linearity correction.

Specific Characteristics of Pressure and Depth

Pressure sensors, which are used in the water industry, are calibrated to provide an output in metres or feet of water depth. The sensors can be ordered as Gauge or Absolute or referenced to one standard atmosphere. A Gauge sensor has one face of the pressure diaphragm exposed to the measuring pressure and the other face exposed to atmospheric air pressure.

A gauge sensor removes measurement errors due to changing atmospheric pressure conditions. For example, if a 2 metre sensor is reading full scale and the atmospheric pressure changes from 1000 millibar to 1020 millibar both faces of the sensor experience the same atmospheric pressure change. This atmospheric change is equivalent to approximately 200mm depth and the sensor will continue to read 2 metres.

Gauge sensors utilise a vent tube to the surface to ensure that the reverse face of the pressure sensor is exposed to atmospheric pressure. Vent tubes are generally encased in the sensor cable that connects the pressure sensor to the measuring instrument on the surface. The use of vent tubes is a very practical means of balancing atmospheric changes but care should be taken with their deployment. (See field deployment)

Absolute sensors have their reverse face enclosed and fixed at zero pressure whereas others can be referred to one-standard atmosphere. These have an advantage that a vent tube is not necessary but the disadvantage is in shallow depths, where the atmospheric pressure must be independently and accurately monitored to compensate for the significant errors due to atmospheric changes. It tends to be a problem when long term monitoring is undertaken at shallow depths where a change in the magnitude of 200mm will cause significant errors.

Water Density and Gravity

When pressure sensors are used for depth readings of any fluid the density becomes an important parameter. In Australia a standard describes the relationship between force and water depth:

Australian Standard AS1376-1973 *

1kPa = 102.15 mm of pure water. @20degC

There is typically a 3% difference in the density between pure water and seawater. This difference should be considered when particular measurement accuracy's are required.

Another factor affecting calibration accuracy is gravity. The departure from standard gravity in Warwick, Qld is -0.17%. at latitude 27.973 deg, height 458m above sea level.

All Greenspan sensors are corrected for gravity as part of their calibration.

**For conditions, see Clause 1.3.8.3 Australian Standard AS1376*

HARDWARE

Sensor Design

The Greenspan PS700 pressure sensor consists of the following primary elements:

- Ceramic capacitance pressure transducer (sensing element)
- Signal conditioning and output circuit
- Data cable with/without vent tube
- 316 Stainless Steel packaging

Transducer

A transducer provides a means of transferring one physical parameter to another i.e. pressure to electrical current or force to current. The pressure transducer utilises the capacitive principle of measurement. Pressure variations on a diaphragm are detected relative to a fixed second plate to produce a signal that is linear over a fixed pressure range. The transducers are available in various ranges. The overpressure rating of the transducer is up to 60 times the full scale rating.

The sensor face is made of a ceramic material (96% Aluminium Oxide, a highly resistant surface for many aggressive gases and liquids).

Signal Conditioning Circuit

This unit performs the following tasks:

- Provides a constant voltage to drive the ceramic sensor capacitance circuit.
- Monitors the output voltage from the ceramic sensor.
- Provides 4-20mA output suitable for data acquisition or process control.
- Accepts any supply voltage between 8-30VDC.

The sensor requires at least one second from power on to ensure full accuracy of reading.

Data Cable and Vent Tube

The data cable consists of the following:

- Outer sheath of wall thickness 1.2 +/-0.3mm, Polyurethane.
- Twelve cores of which two inner cores of 7 strand x 0.2mm copper, PVC sheathed are used.
- Vent tube of approximately 3mm diameter nylon for atmospheric pressure equilibration
- Aluminium earth shield and drain wire

The cable has a resistance of 9 ohms per 100m of conductor. Two conductors are used in a two wire system. Therefore, if 25m of cable is used with a 4-20mA sensor the total voltage drop across the cable at full scale is:

$$= (\text{Full scale} \times 25 \times 0.09) \times 2$$

$$= 20\text{mA} \times 2.25 \times 2 = 90 \text{ millivolts}$$

Therefore to ensure that the minimum open loop voltage at the sensor is at least 10 volts a supply voltage of $10 + 0.090 = 10.09\text{V}$ is required. Typical supply voltages are 12V.

Protection

The sensors are protected against reverse voltage connection and transient voltages up to 2KV such as may occur during lightning storms. However, if used in areas prone to lightning activity it is recommended that lightning arresters be fitted to all input cables.

Pressure Venting System

When vented pressure sensors are deployed, there is usually a difference between the atmospheric temperature and the water temperature of the sensor at depth. This potential temperature differential can cause a pumping effect to occur whereby moist air from the surface is drawn into the sensor through the vent line. This moisture can condense on sensitive electronic components due to warm surface air cooling inside the sensor. Sealing the system against exposure to the atmosphere and conditioning the existing air prior to entering the vent tube will alleviate this problem.

The Greenspan CVS-001 is an air drying system designed to fix these problems. Silicon desiccant crystals easily absorb moisture thereby drying the air and are used in the CVS-001 closed venting system. It is highly recommended that CVS-001 be installed on all Greenspan vented sensors.

The effectiveness of the closed venting method is compromised if the system is disassembled. Therefore, once installed or reassembled, some time is required for trapped air to become dry again. One advantage of this method is that the volume of air being dried is always constant therefore the desiccant crystal will not become saturated. Replacement of breather bags should not be necessary unless they are physically damaged.

MODEL CVS-001

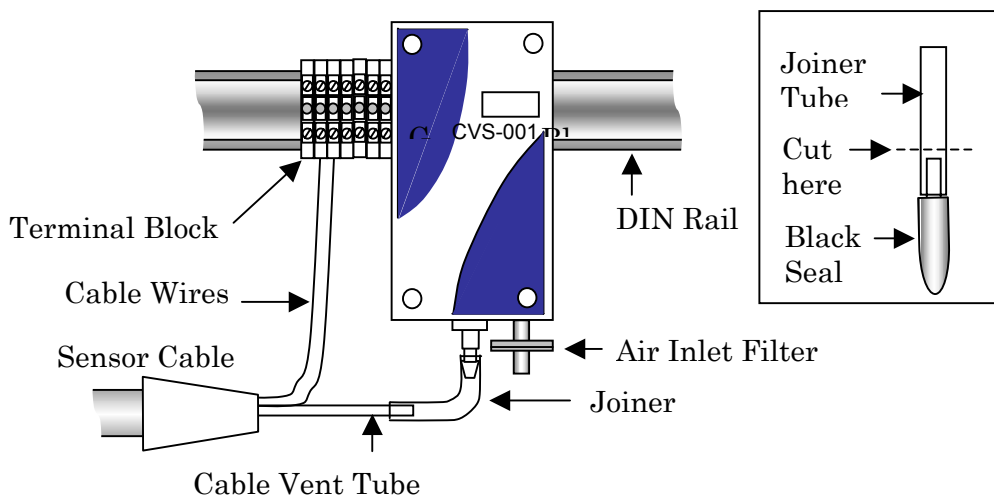

Figure 1. Single Installation, (Suggestion Only)

Remove the seal by cutting the end of the joiner tube with a sharp knife prior to connection. See inset, figure 1.

Figure 1 shows one arrangement possible for fitting CVS-001 to the sensor. A single CVS-001 is designed to handle sensor cable lengths up to **70 metres**. Multiple units may be connected together to increase the capacity. (CVS-002, CVS-003, CVS-004).

Setup

The CVS-001 is shipped with a protective seal on the air inlet tube, **please ensure that this seal is cut off and removed when installing.**

For correct operation of the breather system it is necessary to partially inflate the breather bag inside the CVS-001 to enable it to expand and contract with atmospheric pressure changes.

1. Remove joiner tube from cable vent tube. See Figure 1.
2. Attach 60ml syringe to joiner tube and withdraw all air from breather bag.
3. Remove syringe, recharge, and apply 60ml, remove syringe, recharge and repeat for a further 60ml (total 120ml).
4. Re-connect joiner tube to cable vent tube.
5. If multiple units are being used the volume of air required for priming must increase by approximately 120ml for every unit connected.

Note: Only remove the seal on the CVS-001 inlet when ready to install sensor vent tube. If dismantling the system ensure that the unit is sealed as quickly as possible.

SENSOR MANUFACTURE

4

Quality Control Procedures

The following describes the quality process Greenspan implements to ensure that the documented specifications are consistently met.

- Each ceramic sensor is visually inspected before use.
- The sensor may be selected for temperature performance.
- The sensor is assembled and calibrated to the required range.
- The sensor is tested on a dead weight calibrator to check linearity.
- All results are documented according to ISO9002 requirements (license N0:QEC3067).
- The instrument is visually inspected, marked and labelled.
The complete sensor calibration record is archived for reference, and batch number information is kept on file for statistical analysis.
- The instrument is checked by an independent technician (Quality Control) to confirm correct operation of the sensor/system prior to shipment.
- An individual Certificate of Conformance is issued to the customer.

INSTALLATION

Connection

The sensor is connected to the data logger as follows:

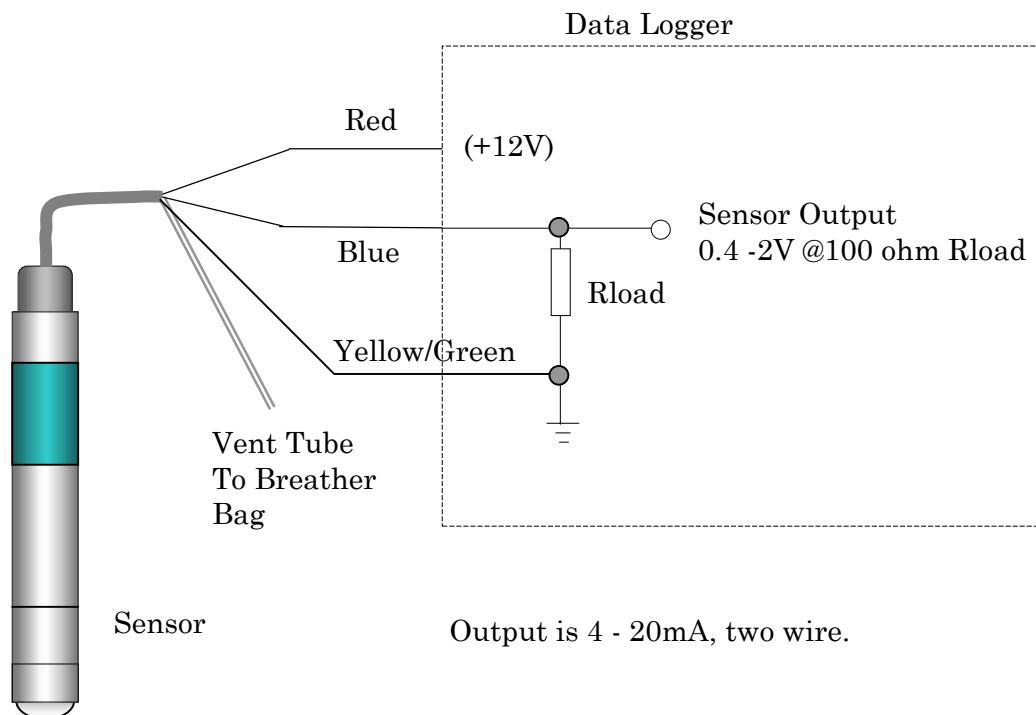

Diagram 1. Connection

Minimum open loop voltage = 10Volts @100 ohms

Maximum open loop voltage = 30Volts

The red (+12V) and blue (output), wires supply power to the PS700 sensor and provide the current loop for 4-20mA.

The Yellow/Green earth wire is for connection to a known earthing point as protection from induced electromagnetic disturbances.

Field Installation Instructions

The Greenspan Range of Pressure Sensors and Water Quality Sensors can be installed into a variety of applications including:

- Rivers, Lakes and streams
- Bore Hole and groundwater wells
- Tanks and Reservoirs
- Wet Wells for Water and Sewer Systems

In all field applications, mechanical, electrical and physical protection of the Sensor, cabling and associated fittings must be provided.

Consideration needs to be given for the protection against vandalism, animal damage, theft and extreme weather conditions.

Field Installation must ensure:

- The sensor is anchored or held in position or located so it is not subject to any movement during normal operations.
- Sensor is protected from direct sunlight to avoid high temperature fluctuations
- Sensor is protected against high turbulence and possible debris loading during flow events

Option 1: Non Turbulent Conditions

Where there is no possibility of the sensor being affected by turbulence it can be suspended into the water body using a stainless steel hanger cable. For example where the sensor is installed into a large water storage tank. The sensor will hang vertically into the tank and not be subject to movement from water movements. The stainless steel wire prevents loading of the sensor cable.

In Sewer Wet Well and Water Tank applications where high turbulence and debris loading may affect the sensor, the following minimum installation standards must be followed:

Option 2: High Turbulent Conditions

Where turbulence and water movement will act on the sensor it is recommended to mount the sensor in a stilling well or mounting cradle attached to the side of the well. This could simply be a length of PVC pipe bolted to the well wall in which the sensor is located or could be an extension pole with a sensor cradle at the lower end. Potential ragging and debris build up on the sensor & cable should be overcome by extending the stilling well to above the high water level or by cable tying the sensor cable up the cradle mounting arm. The movement of the sensor must be eliminated such that the sensor is not subject to twisting motion from swirling water during pumping, or from sideways movement due to ragging of the sensor.

In all sewer wet well applications regardless of the mounting system used it is recommended to also utilise a stainless steel hanger wire to prevent loading the sensor cable during installation, removal and maintenance. The stainless steel wire must be securely connected to the sensor using the hanger hook and the sensor cable should be cable tied at regular intervals up the stainless wire. An outer sheath of hose or tubing can be fitted over both cables to reduce ragging and debris build up on the cables. At the top of the well the stainless wire can be attached to a bolt or mounting point.

The stainless steel suspension hanger cable can be provided by Greenspan. (Part No 7SK-100)

Warning:

Under no circumstances must the sensor be installed such that it can collide with the sides of the well, or other solid objects within the well. Sensor installation under these circumstances will lead to sensor damage which will not be covered under our normal warranty conditions. In these cases the sensor must be mounted into a cradle or stilling well as per Option 2.

Atmospheric Venting of Depth Sensors

Where an atmospheric vent tube is used it must be protected from moisture entry using the Desiccant pack or closed breather vent system. The vented cable must be terminated using the Greenspan Closed Vent System in accordance with manufacturers recommendations.

Sensor Nose Cones

Sensor Nose cones must be securely installed, checked and cleaned as required. Excessively high turbulence in sewer wet wells can cause nose cones to become loose and unscrew themselves. In these applications the nose cone can be fitted with a rubber o-ring (supplied) to act as a thread locking device.

Other Considerations

Environmental compatibility should be checked before using the sensors and advice sought from Greenspan if any doubt exists. The 316 stainless body can be used in a majority of situations but care should be taken against possible corrosion in high Chloride, Sulphate or Ferric solutions.

The body should always be totally immersed under the water to ensure that the sensor is at water temperature and to also avoid any possible anodic/cathodic action taking place on the stainless body at the water-air interface. At some sites it has also been noticed that clamps used to support the sensor made of a dissimilar metal to the 316 stainless body can cause spot corrosion due to electrolysis.

CLEANING AND MAINTENANCE

6

The sensor may be cleaned using a soft cloth and warm water, encrustation or barnacle growth may have to be removed with a scraping action.

Greenspan recommends calibration is checked every six to twelve months.

Greenspan offers a re-calibration service if required.

1. If output readings appear incorrect, disconnect the pressure sensor from the logger and connect a milliammeter in series with the supply and the pressure sensor output. In air, with zero pressure applied and with the sensor head vertically oriented, the reading should be 4.00mA. If the readings are still incorrect and other possible causes have been eliminated then contact Greenspan.
2. If there appears to be no output from the pressure sensor channel, check external connections are correct, (see connection diagram) and that power is 12V and turned on.

APPENDIX

SPECIFICATIONS*

Specification	Model PS700																		
Standard Ranges available:	<table> <thead> <tr> <th>Range</th> <th>Max Overload</th> </tr> </thead> <tbody> <tr><td>0-1m</td><td>60m</td></tr> <tr><td>0-2.5m</td><td>60m</td></tr> <tr><td>0-5m</td><td>60m</td></tr> <tr><td>0-10m</td><td>100m</td></tr> <tr><td>0-20m</td><td>180m</td></tr> <tr><td>0-40m</td><td>250m</td></tr> <tr><td>0-100m</td><td>400m</td></tr> <tr><td>0-200m</td><td>400m</td></tr> </tbody> </table>	Range	Max Overload	0-1m	60m	0-2.5m	60m	0-5m	60m	0-10m	100m	0-20m	180m	0-40m	250m	0-100m	400m	0-200m	400m
Range	Max Overload																		
0-1m	60m																		
0-2.5m	60m																		
0-5m	60m																		
0-10m	100m																		
0-20m	180m																		
0-40m	250m																		
0-100m	400m																		
0-200m	400m																		
Operating Temperature (compensated)	-5 to +60°C																		
Linearity (Combined Linearity, Hysteresis and Repeatability)	± 0.1% FS																		
Temperature stability at offset	± 0.25% FS (over range 0-50°C)																		
Zero Offset & FS Max Variation	± 0.02mA																		
Long Term Stability	better than 0.1% pa																		
Supply Voltage	8-30VDC Reverse polarity protected Surge protected to 2kV																		
Quiescent Current	4 mA																		
Warm up time to stable reading	2 Seconds																		
Output	4-20mA																		
Dimensions	Length 190 mm, Diameter 22 mm																		
Wetted Materials	316 Passivated Stainless steel, Ceramic, Viton, Delrin, Polyurethane																		
Loading	<table> <tbody> <tr> <td>Minimum open loop voltage</td> <td>= 10Volts @100 ohms</td> </tr> <tr> <td>Maximum open loop voltage</td> <td>= 30Volts</td> </tr> </tbody> </table>	Minimum open loop voltage	= 10Volts @100 ohms	Maximum open loop voltage	= 30Volts														
Minimum open loop voltage	= 10Volts @100 ohms																		
Maximum open loop voltage	= 30Volts																		
Storage Temperature	- 20 to +60°C																		
Weight (excluding cable)	320gm (potted)																		

**Specifications subject to change*

PRESSURE SENSOR



22 Palmerin Street, Warwick 4370 Qld
Australia.

Tel: 0746 601888 Fax: 0746 601800

CERTIFICATE of CONFORMANCE

Customer:

Model No. **PS700**

Re:

Product Information

Serial No.	001234	Cable Length	20 metres
Range	0 - 10 m H ₂ O	Supply Voltage	8- 30 VDC
Output	FS 20.00 mA Zero 4.00 mA	Connection	+ve Red Gnd Blue Shield Yellow/Green
Linearity*	+/- 0.1% FS	Connection Code	BW2
Zero Offset	+/- 0.02mA	For connection detail please refer to Connector Chart supplied.	
FS Max Variation	+/- 0.25% FS		
Temperature Stability@ Offset	(over 0-50°C)		
Sensor Type	Gauge		

User Notes

1. Australian Standard, AS1376 is used to convert kPa to metres of water. (1kPa = 10.15 mm water).
2. Do not attempt to dismantle the sensor as it will void the warranty. Contact your agent for technical advice.
3. The sensor is protected against reverse polarity connection.
4. The sensor is fitted with a lightning protector/surge device.
5. All sensors include a 1/4" tapered BSP thread for external fitting.
6. Warm up time to stable reading is 2 seconds.

Inspected By : / /