

*Electrical Conductivity
Sensor
EC1200*

Edition 1.5

*User
Manual*



Greenspan Customer Service
+61 7 4660 1888

Technical Support When You Need It

The correct choice of sensor should be supported by professional advice to ensure long term success in the field. **Greenspan Technical Services** is dedicated to customer support and provides assistance in the selection, installation, deployment and commissioning of sensors with a full range of consulting services.

A full technical support and field advice service can be accessed by ringing **Customer Service** on +61 7 4660 1888 between 8am - 6pm, 5 days a week.

All requests for information will be serviced within 24 hours.

All Greenspan products are designed, developed and manufactured in Australia and can be supplied at short notice.

Warranty Details

Greenspan warrants all new Greenspan products against defects in materials and workmanship for **12 months** from the date of invoice. During the warranty period, we will repair or, at our option, replace at no charge a product that proves to be defective provided that it is returned, shipping prepaid, to Greenspan Technology Pty Ltd.

Greenspan's liability and obligations in connection with any defects in materials and workmanship are expressly limited to repair or replacement, and the sole and exclusive remedy in the event of such defects shall be repair or replacement. Greenspan's obligations under this warranty are conditional upon it receiving prompt written notice of claimed defects within the warranty period and its obligations are expressly limited to repair or replacement.

This warranty does not apply to products or parts thereof which have been altered or repaired outside of the Greenspan factory or other authorised service centre, or products damaged by improper installation or application, or subjected to misuse, abuse neglect or accident. This warranty also excludes items such as reference electrodes and Dissolved Oxygen membranes that may degrade during normal use.

Greenspan Technology Pty Ltd will not be liable for any incidental or consequential damage or expense incurred by the user due to partial or incomplete inoperability of its products for any reason whatsoever or due to inaccurate information generated by its products.

All Warranty service will be completed as soon possible. If delays are unavoidable customers will be contacted immediately.

The sensors should not be dismantled unless under instruction from Greenspan. Incorrect handling will void the warranty.

Contents

1.	<i>Introduction to the EC1200 Sensor</i>	5
	<i>1.1 Overview</i>	5
2.	<i>Packaging</i>	5
3.	<i>Unpacking Your EC1200 Sensor</i>	6
4.	<i>Checking the Model Number and Range</i>	6
5.	<i>Testing Your System</i>	6
6.	<i>General Methods of Installation</i>	7
	<i>6.1 Typical Locations</i>	8
	<i>6.2 Field Installation Instructions</i>	8
	<i>6.3 Option 1: Non Turbulent Conditions</i>	9
	<i>6.4 Option 2: High Turbulent Conditions</i>	9
	<i>6.5 Other Considerations</i>	10
7.	<i>Sensor Maintenance</i>	11
	<i>7.1 EC Field Considerations</i>	11
8.	<i>Operation</i>	12
9.	<i>Extended Commands</i>	12
	<i>9.1 User Gain</i>	12
	<i>9.2 User Offset</i>	12
	<i>9.3 Zero Channel</i>	12
	<i>9.4 Reading data from the Greenspan EC1200</i>	12
10.	<i>Calibration</i>	13

10.1 EC Quick Check and Re-Calibration Method.....	13
10.1.1 Introduction.....	13
10.1.2 Checking Only.....	13
10.1.3 Re-Calibration	13
10.2 Calibration of EC Calibrator to Sensor.....	15
10.2.1 Electrical Conductivity to Salinity Conversion	15
10.3 Temperature Calibration.....	16
11. Maintenance.....	17
12. Specifications	18

1. Introduction to the EC1200 Sensor

1.1 Overview

The Greenspan SDI-12 sensor range has been designed to allow connection to the SDI-12 serial / digital network widely used in the hydrological and field monitoring industry.

SDI-12 allows multiple connection of sensors to a single data-logging recorder, transmitting at 1200 baud over distances up to 60 metres (200 feet) between each sensor and the data logger.

The EC1200 includes complete linearity correction and temperature correction over a wide range, thereby maintaining its factory accurate calibration while in the field. Each sensor is individually calibrated over span and temperature. The EC1200 conforms to SDI-12 version 1.2.

2. Packaging

Media compatibility should be checked before using the sensor and advice sought from Greenspan if any doubt exists. The 316 stainless body can be used in the majority of situations, but care should be taken against possible corrosion in high Chloride or Ferric solutions.

The body should always be totally immersed under the water to ensure the electronic module is at water temperature and also to avoid any possible anodic / cathodic action taking place on the stainless body at the water-air interface due to oxygen differences across the boundary. It has also been noticed at some sites that clamps used to support the sensors made of dissimilar metal to the 316 stainless body have occasionally caused spot corrosion due to electrolysis action.

An optional Delrin plastic body is available if there is concern with the suitability of the 316 stainless steel.

3. Unpacking Your EC1200 Sensor

Here are the items you should have received.

1. Greenspan EC1200 sensor with polyurethane cable.
2. This User Manual*
3. SDI-12 Command Calibration Reference *

Check the cable is long enough to reach from the depth selected to the data recorder.

* This item can be ordered separately from Greenspan or can be downloaded from <http://www.greenspan.com.au/manuals.htm>

4. Checking the Model Number and Range

Before installing your Greenspan SDI-12 sensor check the information on the label is correct to confirm you have received the instrument you have ordered. The label will look like this.

MODEL	EC1200
RANGE	5000uS/50°C
OUTPUT	SDI-12
S/N	001243

5. Testing Your System

Before installing your Greenspan SDI-12 sensor you may wish to familiarise yourself with its operation. Placing the sensor in a bucket of water and observing your data recorder's readings can do this. This has the added advantage of easy access to a telephone if any questions arise.

6. General Methods of Installation

There are many ways of installing sensors in the field in order to ensure the continuous gathering of data and the safety of the device. Consideration needs to be given to the possibility of vandalism, animal damage, theft and extreme weather conditions. Sensor should always be deployed with the stainless steel drop cable, or damage will result.

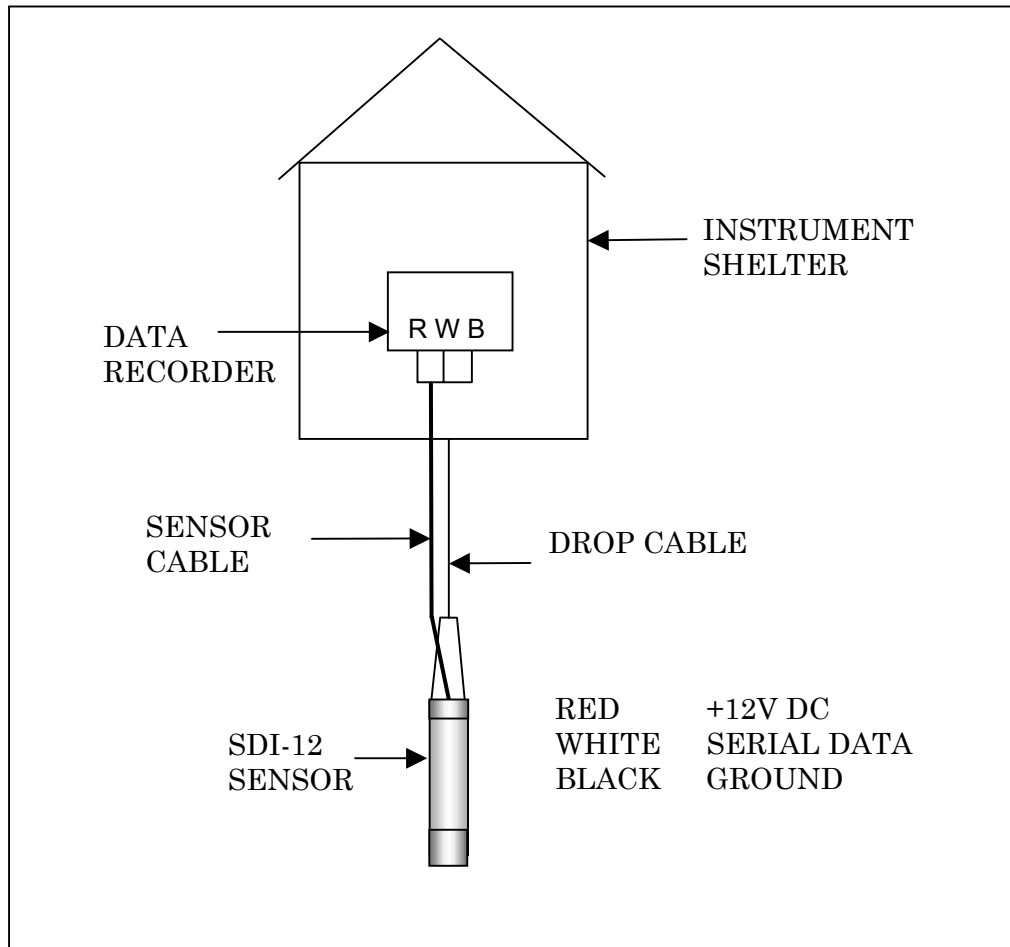

Figure 1. Installation

Note: Additional SDI-12 sensors are wired in parallel to the data recorder.

* Greenspan does not supply the stainless steel drop cable.

Some methods commonly used are:

1. Suspended sensor attached to a guide wire and winch board, which is useful for profiling applications.
2. Fly wire across stream or river, tether the sensor to the fly wire and fully immerse.
3. Installed in PVC conduit with sensor protruding from immersed end.
4. Sealed waterproof, self contained vessel including batteries and continuous logging equipment. Excellent for concealment.
5. Strapped to a pylon or post in areas that become submersed, cabled to bank.

6.1 Typical Locations

1. Suspended above bore hole via drop cable
2. Edge of a river, stream or lake embankment.
3. Side of a boat or vessel.
4. Mounted within a stilling well.
5. Mounted within drainage channels or pipes.
6. Suspended from dam walls.
7. Sensor anchored to bed of lake or stream

6.2 Field Installation Instructions

The Greenspan Range of Pressure Sensors and Water Quality Sensors can be installed into a variety of applications including:

- Rivers, Lakes and streams
- Bore Hole and groundwater wells
- Tanks and Reservoirs
- Wet Wells for Water and Sewer Systems

In all field applications, mechanical, electrical and physical protection of the Sensor, cabling and associated fittings must be provided.

Field Installation must ensure:

- The sensor is anchored or held in position or located so it is not subject to any movement during normal operations.

- Sensor is protected from direct sunlight to avoid high temperature fluctuations
- Sensor is protected against high turbulence and possible debris loading during flow events

6.3 Option 1: Non Turbulent Conditions

Where there is no possibility of the sensor being affected by turbulence it can be suspended into the water body using a stainless steel hanger cable. For example; where the sensor is installed into a large water storage tank. The sensor will hang vertically into the tank and not be subject to movement from water movements. The stainless steel wire prevents loading of the sensor cable.

In Sewer Wet Well and Water Tank applications where high turbulence and debris loading may affect the sensor, the following minimum installation standards must be followed:

6.4 Option 2: High Turbulent Conditions

Where turbulence and water movement will act on the sensor it is recommended to mount the sensor in a stilling well or mounting cradle attached to the side of the well. This could simply be a length of PVC pipe bolted to the well wall in which the sensor is located or could be an extension pole with a sensor cradle at the lower end. Potential ragging and debris build up on the sensor & cable should be overcome by extending the stilling well to above the high water level or by cable tying the sensor cable up the cradle mounting arm. The movement of the sensor must be eliminated such that the sensor is not subject to twisting motion from swirling water during pumping, or from sideways movement due to ragging of the sensor.

In all sewer wet well applications regardless of the mounting system used it is recommended to also utilise a stainless steel hanger wire to prevent loading the sensor cable during installation, removal and maintenance. The stainless steel wire must be securely connected to the sensor using the hanger hook and the sensor cable should be cable tied at regular intervals up the stainless wire. An outer sheath of hose or tubing can be fitted over both cables to reduce ragging and debris build up on the cables. At the top of the well the stainless wire can be attached to a bolt or mounting point.

The stainless steel suspension, hanger cable can be provided by Greenspan. (Part No 7SK-100)

Warning:

Under no circumstances must the sensor be installed such that it can collide with the sides of the well, or other solid objects within the well. Sensor installation under these circumstances will lead to sensor damage which will not be covered under our normal warranty conditions. In these cases the sensor must be mounted into a cradle or stilling well as per Option 2.

6.5 Other Considerations

Environmental compatibility should be checked before using the sensors and advice sought from Greenspan if any doubt exists. The 316 stainless body can be used in a majority of situations but care should be taken against possible corrosion in high Chloride, Sulphate or Ferric solutions.

The body should always be totally immersed under the water to ensure that the sensor is at water temperature and to also avoid any possible anodic/cathodic action taking place on the stainless body at the water-air interface. At some sites it has also been noticed that clamps used to support the sensor made of a dissimilar metal to the 316 stainless body can cause spot corrosion due to electrolysis.

7. Sensor Maintenance

7.1 EC Field Considerations

The toroidal sensors create an electric field around the sensing head, and it is necessary to maintain a space of at least 100mm around the head to ensure complete accuracy.

The sensor should always be completely submerged and positioned so that the possibility of air bubbles becoming trapped within the sensor hole is minimised. Large bubbles cause errors if permanently trapped.

The sensor head should be periodically inspected for fouling, and if needed cleaned with water and a washcloth. The protective shroud is easily unscrewed from the head for quick access. Bottlebrushes are commonly used for cleaning the sensor hole.

Please note that EC sensors fitted with the protection shroud are calibrated in the factory with the shroud on. If the shroud is removed the calibration in water will be affected significantly. This is not a problem if the shroud is removed in air when checking calibration with the EC Calibrator supplied. Please ensure that the shroud is always fitted for normal use in water and only removed while cleaning and checking in air.

When checking the calibration of the EC sensor it is best to select a calibration standard whose Electrical Conductivity is close to the EC of the solution to be measured. For example if a 0 to 5,000 $\mu\text{S}/\text{cm}$ sensor is selected to monitor EC's in the range of 2,000 to 3,000 $\mu\text{S}/\text{cm}$ it is better to check calibration with a standard solution of 2.76 mS/cm (0.02 KCL Molar concentration) in addition to those close to zero and full scale outputs. (Note: pre-prepared EC standards are often specified in mS/cm not $\mu\text{S}/\text{cm}$).

Table 1 below shows KCL solutions and their Electrical Conductivity values:

KCL Molar Concentration	EC (mS/cm)
0.5	58.64
0.2	24.82
0.1	12.90
0.05	6.67
0.02	2.76
0.01	1.41
0.005	0.72
0.002	0.29
0.001	0.15
0.0005	0.07

Sensor Calibration may also be checked without the need for solutions, if preferred. See Section 10, 'Calibration'.

8. Operation

The Greenspan EC1200 combines robust, sealed construction with ease of use. Due to its low power consumption it can be operated from remote power sources for extended periods. The EC1200 outputs EC in $\mu\text{S}/\text{cm}$. The normalisation factor used in Greenspan EC sensors is $K = 1.84\%$ per deg C @ 25°C. Temperature output selection can be in degrees Fahrenheit or Celsius.

The EC1200 contains a microprocessor to provide temperature and linearity compensation, and to control both the offset and full scale settings. This allows for fine adjustments if and when required, as part of regular maintenance. These features are implemented with the extended SDI-12 commands.

Note. Output units for EC and temperature must be specified on order.

9. Extended Commands

Please refer to the SDI-12 Command Calibration Reference for further information on the following commands.

9.1 User Gain

The User Gain command enables re-scaling when calibrating the sensor.

9.2 User Offset

The User Offset command allows the user to modify the offset of the sensor.

9.3 Zero Channel

The Zero Channel command will allow an automatic zero calibration. This command can also be used while the sensor is in place to reference the zero reading to where the sensor is located.

9.4 Reading data from the Greenspan EC1200

Your selected data recorder must be able to read SDI-12 signals. Since data recorders differ widely, you must follow the manufacturers' instructions when reading data. User requirements also differ, so the data recorders need to be programmed individually.

Detailed operation of the SDI-12 standard can be found in the document "A Serial-Digital Interface Standard for Microprocessor-Based Sensors" version 1.2 at web address:

<http://www.sdi-12.org>.

10. Calibration

10.1 EC Quick Check and Re-Calibration Method

10.1.1 Introduction

The following procedures detail a quick method to check and calibrate both full scale and zero using the supplied loop calibrator CK-102.

(All sensors are supplied with a calibrator, for older sensors an EC calibration kit 7CK-102 is available).

Note: For each EC sensor the calibrator is clearly marked with a serial number and calibration value specified at a temperature of 25°C for that sensor. Because the normalised result is derived internally from the non-normalised (EC Raw) calibration, the method below is suitable for both sensor types.

10.1.2 Checking Only

1. Remove the sensor from the water, unscrew the shroud and dry the EC head and temperature button. Let it temperature stabilise in air for at least two hours.
2. For full scale, loop the EC calibrator wires through the EC head and connect together.
3. Obtain the **EC Raw** reading using the *Start Measurement* command, eg: *0M!* This value should be within **+/-1%** of the reference value marked on the supplied calibrator. If the value is not within the error of the reference value then re-calibration is necessary.

10.1.3 Re-Calibration

1. Remove the sensor from the water, unscrew the shroud and dry the EC head and temperature button. Let it temperature stabilise in air for at least two hours.
2. EC requires a 2 point Gain and Offset Calibration.
3. Set current *User Offset Correction* to 0 eg: *0XU0W050!* (Uoffset). Refer to Table 1 in Appendix of SDI-12 Command Manual for channel value.
4. Set current *User Gain Correction* to 1 eg: *0XU1W051!* (Ugain). Refer to Table 1 in Appendix of SDI-12 Command Manual for channel value.
5. The zero value is read **without** the loop calibrator. Use the *Start Measurement* command eg: *0M!* (Meas1). Wait for time out, then use the *Send Data* command *0D0!* to display reading.

6. For full scale, loop the EC calibrator wires through the EC head and connect together.
7. Obtain the **EC Raw** reading using the *Start Measurement* command, eg: *0M!* (Meas2) Wait for time out, then use the *Send Data* command *0D0!* to display reading.
8. To re-calibrate the sensor, calculate the new user gain:

$$\text{Ugain} = \frac{\text{Full Scale}}{\text{Meas2} - \text{Meas1}}$$

where: Full Scale = as marked on calibrator body
 Meas1 = the zero value read **without** the loop calibrator. (step 5 in this section)
 Meas2 = the **EC Raw** value (step 7 in this section)

for example:

If measured **EC Raw** (Meas2) is 2100µS and zero value (Meas1) is 7µS and the full scale of the calibrator is 1950µS:

$$\begin{aligned} \text{new Ugain} &= \frac{1950}{2100 - 7} \\ &= \mathbf{0.931677} \end{aligned}$$

9. Calculate new User Offset correction:

$$\text{new Uoffset} = \text{Full Scale} - (\text{Ugain} \times \text{Meas2})$$

for example:

If Full Scale is 1950µS and Meas 2 is 2100µS

$$\begin{aligned} \text{new Uoffset} &= 1950 - (0.931677 \times 2100) \\ &= \mathbf{- 6.52} \end{aligned}$$

10. Write new *Uoffset Correction*, eg: *0XU0W05-6.52!*. Refer to Table 1 in Appendix of SDI-12 Command Manual for channel value.
11. Write new *Ugain Correction*, eg: *0XU1W050.931677!*. Refer to Table 1 in Appendix of SDI-12 Command Manual for channel value.

10.2 Calibration of EC Calibrator to Sensor

Note this step is only required if EC calibrator has **not** already been calibrated to sensor. Please note this section assumes that the EC sensor has been **recently accurately calibrated**. Because the normalised result is derived internally from the non-normalised (EC Raw) calibration, the method below is suitable for both sensor types.

1. Ensure that the correct calibrator has been supplied for the sensor under test. ie. the serial number should be marked on the body.
2. Remove the sensor from the water, unscrew the shroud and dry the EC head and temperature button. Let it temperature stabilise in air for at least two hours.
3. For full scale connect the EC calibrator through EC head hole.
4. Obtain the **EC Raw** reading using the *Start Measurement* command, eg: *0M!*
5. Write the EC value, (in μS) on body of calibrator. (The sensor serial number should already be recorded on the body).

10.2.1 Electrical Conductivity to Salinity Conversion

A method for the calculation of Salinity values from EC is provided in the form of an Excel spreadsheet. Please contact Greenspan Technology if you require further information or would like to receive a copy of the conversion file on 3.5" disk.

10.3 Temperature Calibration

The temperature calibration is factory set, it is strongly recommend this channel is not re-calibrated by the customer due to difficulties involved in setting up accurate, stable temperature standards.

The method presented here is included for completeness and assumes an accurate temp reference bath.

1. Ensure sensor is connected to power and computer.
2. Set up a low temperature stable bath (0-10°C)
3. Immerse the sensor in the bath (sensor should be completely covered) and allow two hours for sensor to stabilise to bath temperature.
4. Temperature calibration requires a 2 point Gain and Offset Calibration.
5. Set current *User Offset Correction* to 0 eg: *0XU0W040!* (Uoffset). Refer to Table 1 in Appendix of SDI-12 Command Manual for channel value.
6. Set current *User Gain Correction* to 1 eg: *0XU1W041!* (Ugain). Refer to Table 1 in Appendix of SDI-12 Command Manual for channel value.
7. Obtain the low point using *Start Measurement* command for temperature. eg: *0M!* (Meas1). Wait for time out, then use the *Send Data* command *0D0!* to display reading.
8. Immerse the temp sensor in the hot water bath, (approx. 40- 50°C). Allow two hours for temperature to stabilise. Most sensors have the temperature reference device mounted internally and therefore require the airspace around them to equilibrate to case temperature.
9. Obtain the high point using *Start Measurement* command for temperature. eg: *0M!* (Meas2). Wait for time out, then use the *Send Data* command *0D0!* to display reading.
10. To re-calibrate the sensor, calculate the new user gain:

$$U_{\text{gain}} = \frac{\text{Full Scale}}{\text{Meas2} - \text{Meas1}}$$

where: Full Scale = 50°C

for example:

If measured temperature (Meas2) is 45°C and measured low value (Meas1) is 5°C

$$\begin{aligned} \text{new } U_{\text{gain}} &= \frac{50}{45 - 5} \\ &= \mathbf{1.25} \end{aligned}$$

11. Calculate new *User Offset Correction*:

$$\text{new Uoffset} = \text{Full Scale} - (\text{Ugain} \times \text{Meas2})$$

for example:

If Full Scale is 50°C and measured temperature is 45°C

$$\begin{aligned}\text{new Uoffset} &= 50 - (1.25 \times 45) \\ &= \mathbf{-6.25}\end{aligned}$$

12. Write new *User Offset Correction*, eg: *0XU0W04-6.25!*. Refer to Table 1 in Appendix of SDI-12 Command Manual for channel value.
13. Write new *User Gain Correction*, eg: *0XU1W041.25!*. Refer to Table 1 in Appendix of SDI-12 Command Manual for channel value.
14. The Temperature channel is now re-calibrated and ready for use.

It is recommended calibration is checked every six months.

11. Maintenance

The sensor may be cleaned using a soft cloth and warm water, encrustation or barnacle growth may have to be removed with a scraping action.

Greenspan recommends calibration is checked every six to twelve months. Adjustments can be made using the SDI-12 commands detailed in this manual or returned to Greenspan for re-calibration.

12. Specifications

Specification

Model EC1200

Standard ranges available	0-1000 μ S 0-2000 μ S 0-5000 μ S 0-10,000 μ S 0-20,000 μ S 0-60,000 μ S
Operating Temperature	0 to +50°C
Baud Rate	1200 baud
Address Range	00 to 09 A to Z
Electrical Conductivity Accuracy Normalised to 25°C Non-Normalised	$\pm 1\%$ Full Scale, (over 0-35°C) $\pm 0.7\%$ Full Scale, (over 0-50°C)
EC Normalisation Factor	K = 1.84% per deg C @ 25°C
EC Linearity	$\pm 0.2\%$ Full Scale
Temperature Accuracy	$\pm 0.2^\circ\text{C}$
Output	SDI-12
Supply Voltage	9-16VDC
Standby Current Comms Current Measurement Current	<200 μ A <15mA <60mA
Reading Time	2 seconds
Cable	Polyurethane outer-sheath Maximum length 60 metres
Dimensions: Length Diameter	393mm 44mm Stainless Steel 47mm Delrin
Wetted materials	316 Stainless Steel and Delrin
Weight	786g Delrin 991g Stainless Steel