

**INSTRUCTION MANUAL**  
**TIPPING BUCKET RAINGUAGE**  
**MODEL TB3**

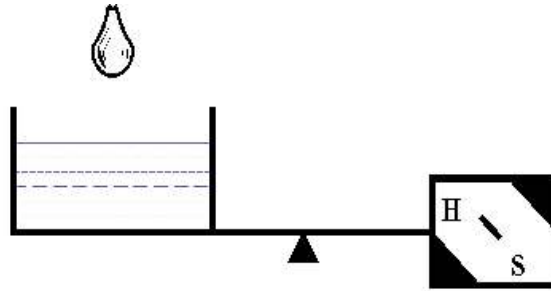

QUALITY SYSTEM  
**ISO**  
**9001**  
1994  
CERTIFIED

**HYDROLOGICAL SERVICES PTY LTD**  
PO BOX 332, LIVERPOOL B.C NSW 1871, AUSTRALIA  
Phone:(Int.) 612 9601 2022 Fax: :(Int.) 612 9601 6971  
Phone:(Nat.) (02) 9601 2022 Fax: :(Nat.) (02) 9601 6971  
Email: hydros@ozemail.com.au

## HYDROLOGICAL SERVICES

---

### CONTENTS

I.	Hydrological Services Standard Warranty Terms	TB3 100-03
II.	General	TB3 100-04
III.	Unpacking your TB3	TB3 100-04
IV.	Specification	TB3 100-05
V.	Installation	TB3 100-06
VI.	Test Operation	TB3 100-07
VII.	Maintenance	TB3 100-08
VIII.	Electrical	TB3 100-09
IX.	Calibration	TB3 100-09
X.	Schematic Layout TB3	TB3 100-10
	Parts List	TB3 110-01
	FCD Instruction	TB3 110-02

## HYDROLOGICAL SERVICES

---

### I. HYDROLOGICAL SERVICES STANDARD WARRANTY TERMS

#### WARRANTY, DISCLAIMER AND LIMITATION OF LIABILITY:

We warrant this product to be free from defects in material and workmanship for a period of one year from the date of shipment hereof or its total rated life whichever first occurs. During the warranty period, we will repair or replace this product if it is returned to us with shipping charges prepaid and we determine it to be defective. This warranty shall not apply if this product has been subjected to misuse, negligence, accidents, or misapplied, or modified or repaired by unauthorised persons, or improperly installed, and we shall not be liable to any person for personal injury or property damage caused by such a product.

All other warranties, express and implied, including warranties of MERCHANTABILITY And FITNESS FOR A PARTICULAR PURPOSE, are disclaimed. All other remedies and liabilities, including incidental, consequential, and special damages, losses and expenses, are excluded.

Note: It is Hydrological Services' policy to support all of our products. If design or workmanship problems arise after this statutory warranty period we request that you contact us.

### **TIPPING BUCKET RAINGUAGE MODEL TB3**

#### **II. GENERAL**

The Hydrological Services Tipping Bucket Raingauge (TB3) is recognised as the standard for measuring rainfall and precipitation in remote and unattended locations. The TB3 raingauge operates on the tipping bucket principle, and has two types of buckets; metal and plastic. A receiver of 200mm diameter collects the rainfall, which is strained by a metal gauze before being passed to the tipping bucket measuring system. Tips of the metal bucket occur with each 0.2mm, 0.5mm, 1.0mm or 0.01 inch of precipitation collected, and tips of the plastic bucket occur with each 0.2mm/p, 0.5mm/p or 0.010/p of precipitation collected. A reed switch detects these events and produces a momentary contact closure signal for:

- logging in our Rainfall Data Logger
- transmission by our Radio Reporting Raingauge, or
- display on our Rainfall Counter.

#### **III. UNPACKING YOUR TB3 RAINGAUGE**

- This package should contain:
- TB3 Raingauge
- TB311 10 metre connecting lead
- This manual

Please verify you have received these items and that the Tipping Bucket Raingauge resolution is as ordered.

To prepare the Tipping Bucket Raingauge for installation:

- lift the unit from the carton and place on secure surface
- remove polythene bag
- loosen the three enclosure securing screws and back them off until screw head is clear of the enclosure.
- lift the enclosure from the gauge
- carefully remove the elastic band/support pad from the bucket.

Your Tipping Bucket Raingauge is now ready for installation.

## HYDROLOGICAL SERVICES

---

### IV. SPECIFICATION

Receiver:	200 mm $\pm$ 0.3 diameter machined aluminium rim. Powder coated.
Bucket capacity:	0.2 mm, 0.5 mm, 1.0 mm or 0.01 inch of rainfall.
Sensitivity:	one tip.
Measuring range:	0 to 700 mm / hr.
Calibration accuracy:	$\pm$ 2 % for intensities from 25 to 500 mm/hr. Long term stable calibration.
Humidity:	0 to 100 %
Temperature:	- 20 to +70 C
Contact system:	dual reed switches potted in soft silicon rubber with varister protection.
- Max Capacity:	12 VA (0.5 amp max.)
- Resistance:	Initial contact resistance 0.1 OHMS
- M.T.B.F:	$10^8$ to $10^9$ Operations
Syphon:	0.4 mm capacity of rainfall - made from brass with a non hydroscopic outer case. The syphon can be dismantled for routine cleaning and servicing.
Bucket:	Two types of buckets, synthetic ceramic coated brass bucket balanced to $\pm$ 0.05 gms, and injection moulded non hydroscopic plastic ABS balanced $\pm$ 0.05gms.
Base:	Diecast aluminium.
Level:	bulls eye level adhered to aluminium base.
Mounting holes:	three 10 mm diameter mounting holes with 117 mm p.c.d. cast in feet attached to outside diameter of base.
Drain fittings:	to attach 12 mm inside diameter tubing, to catch rainfall after passing through buckets.
Pivots:	ground sapphire pivots with hard stainless steel shaft.
Insect covers:	stainless steel mesh on all openings to prevent insects and ants entering gauge.
Outer enclosure:	keyed to enable the release of the outer enclosure without the need for the removal of the three securing screws.
Height:	342mm
Weight:	3 kg
Packed Dimensions:	5 kg 0.03m <sup>3</sup>

V. INSTALLATION

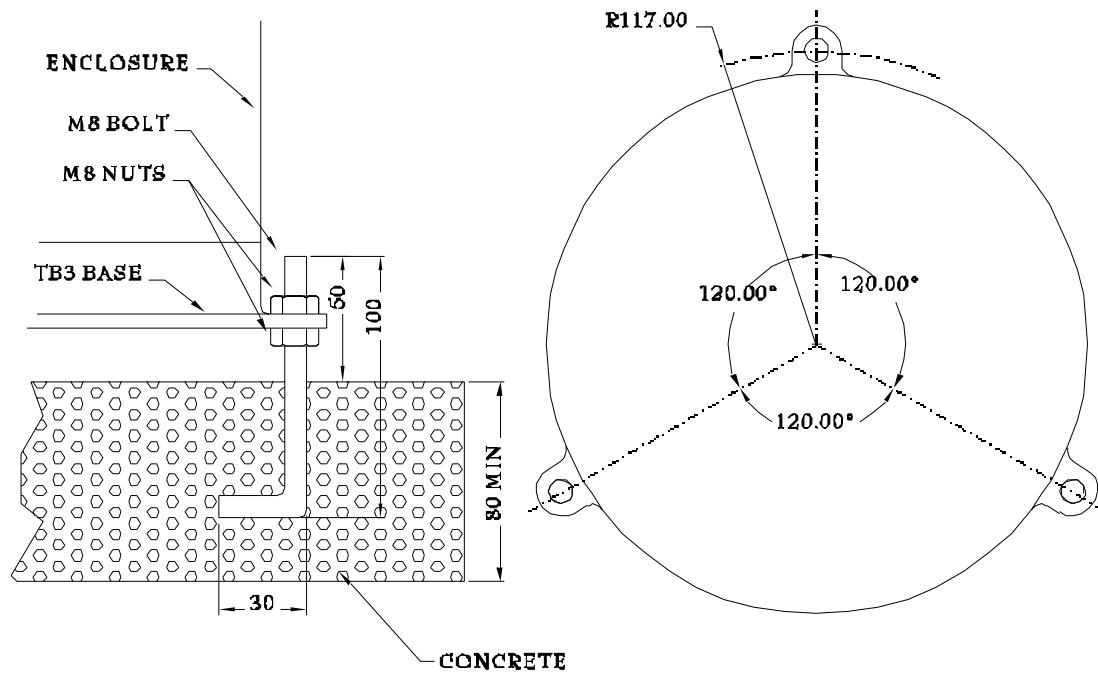

DIAGRAM 1

i. Site Selection

Rainfall measurements are intended to be representative of the actual rain falling on a given area. Some of the more important factors which influence the representativeness of a gauge are as follows:

- Site the gauge on level ground where possible. Avoid sloping sites.
- Site should have adequate protection from strong winds.
- Site should be free of large obstructions such as buildings and trees.
- Provide suitable ground surface to avoid splashing into the gauge.

### ii. Setting up

- Install the gauge on the foundation. A suggested foundation is shown in Diagram 1.
- Loosen the three enclosure securing screws and the enclosure.
- The gauge is provided with a level. Proceed to level by adjusting the hold down anchors as required.
- Connect lead to the rain gauge terminals, in accordance with Diagram 3, and to the recording device, in accordance with manufacturer's instruction manual.

### VI. TEST OPERATION

- Manually tip the bucket a number of times, ensuring that each tip is being recorded and that the tilting mechanism is operating freely.
- Replace and secure the enclosure.

### VII. MAINTENANCE

The only routine maintenance required is cleaning. The following items should be checked regularly for cleanliness:

- **Catch filter**
- **Syphon**

#### i. Dismantle Details

- Unscrew nut
- Lightly press stem down on surface until stem pops out of syphon body.
- Remove stem from syphon body.
- Unscrew cap
- Clean all items

#### ii. Assembly Details

- Screw cap on stem. Finger tight only.
- Push stem into syphon body.
- Replace nut and tighten. Do not over tighten.

- **Interior of bucket**
- **Top surface of adjusting screws**
- **Enclosure locking screws** - lightly lubricate after cleaning
- **All insect screens**

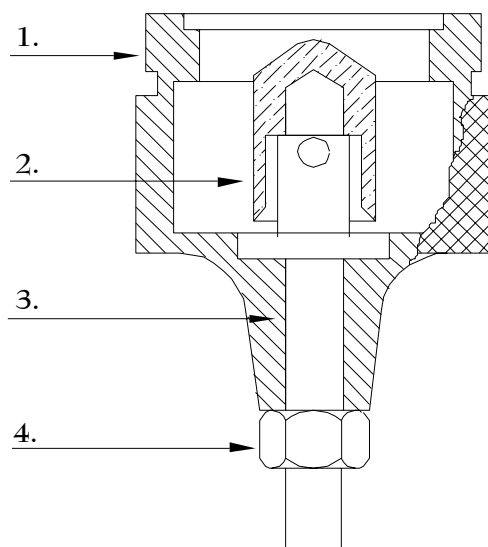

1. SYPHON BODY TB309-01
2. STEM CAP TB309-02
3. SYPHON STEM TB309-03
4. HEX NUT BRASS SCO08-38

DIAGRAM 2

### VIII. ELECTRICAL

Dual reed switches are provided for several reasons:

- Two isolated switches permit the control of two separate circuits; e.g. a local counter and a telemetry circuit.
- Parallel connection of both switches increases the current carrying capacity of the contact system if required.
- Parallel switch operation confers a degree of redundancy in locations where data from the raingauge is critical to flood warning etc.

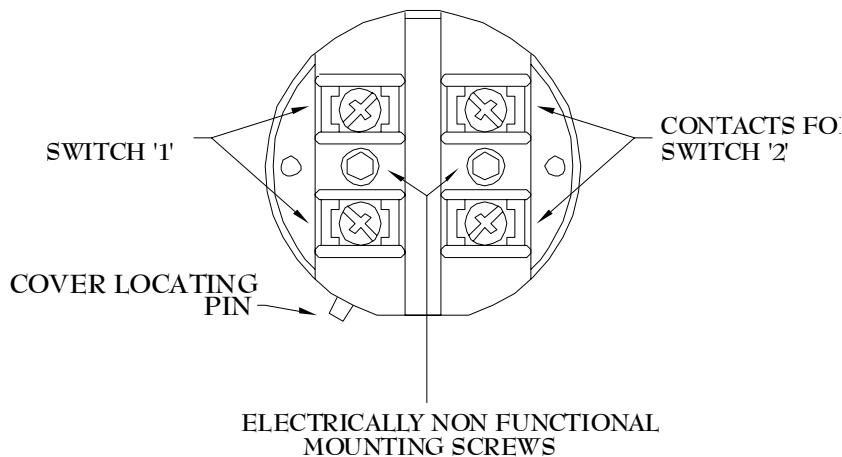

### IX. CALIBRATION

All gauges have been calibrated by Hydrological Services Pty Limited prior to despatch.

The following products and services are available from Hydrological Services Pty Ltd.:

- Field Calibration Device, Model TB320, for routine field check calibrations, supplied with operating instruction sheet.
- Laboratory Calibration Unit, Model TB340, for calibration after servicing in workshops, supplied with operating manual.
- Recalibration Service at Hydrological Services' factory.

Please contact either Hydrological Services Pty Ltd or our local distributor for further information.

X. SCHEMATIC LAYOUT TB3

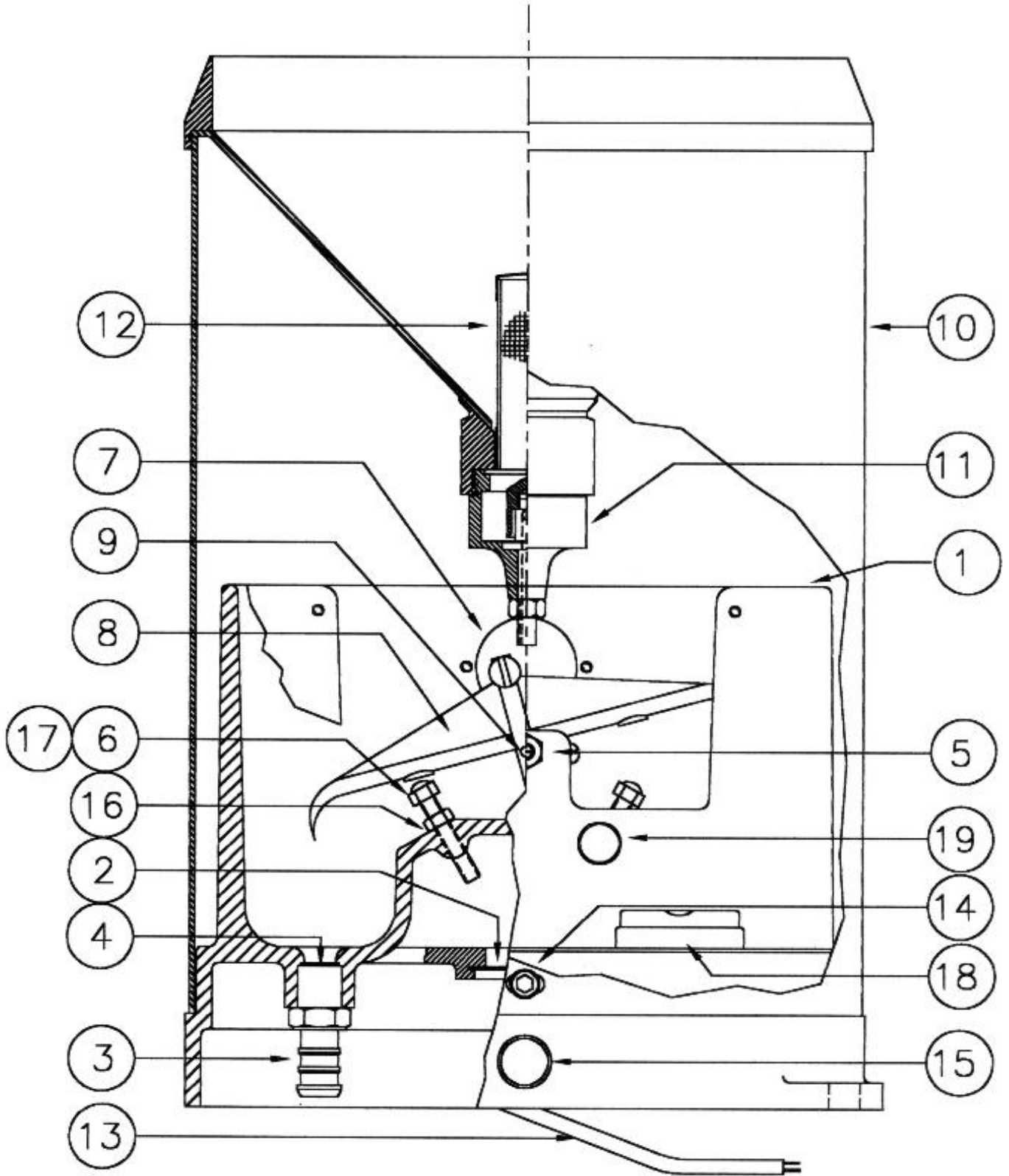

DIAGRAM 4

## HYDROLOGICAL SEVICES

### PART LIST

ITEM	DESCRIPTION	PART NO.	QTY/ASSY
1	BASE	TB301-01	1
2	INSECT SCREEN	TB301-03	2
3	FITTING	TB301-07	2
4	INSECT SCREEN	TB301-02	2
5	PIVOT SCREW C/W NUT	TB301-05	2
6	ADJUSTING SCREW	TB312	2
7	ASSY REED SWITCH	TB303	1
8	ASSY BUCKET (METAL)	TB304 (0.2 mm) TB305 (0.5 mm) TB306 (1.0 mm) TB304 (0.01 inch)	1
	ASSY BUCKET (PLASTIC)	TB314 (0.2 mm) TB316 (0.5 mm) TB317 (0.01 inch)	
9	BUCKET AXLE	TB304-03	1
10	ASSY ENCLOSURE	TB308	1
11	ASSY SYPHON	TB309	1
12	ASSY FILTER	TB310	1
13	CONNECTING LEAD	TB311	1
14	SCREW	SC045-21	3
15	GROMMET	SC040-20	1
16	LOCK NUT	SC008-24	2
17	SCREW	SC022-08	2
18	BULLSEYE LEVEL	SC023-09	1
19	KNURLED HEAD LOCK SCREW	TB301-04	2

**NOTE: PLEASE WET RAINGUAGE PRIOR TO CALIBRATION**

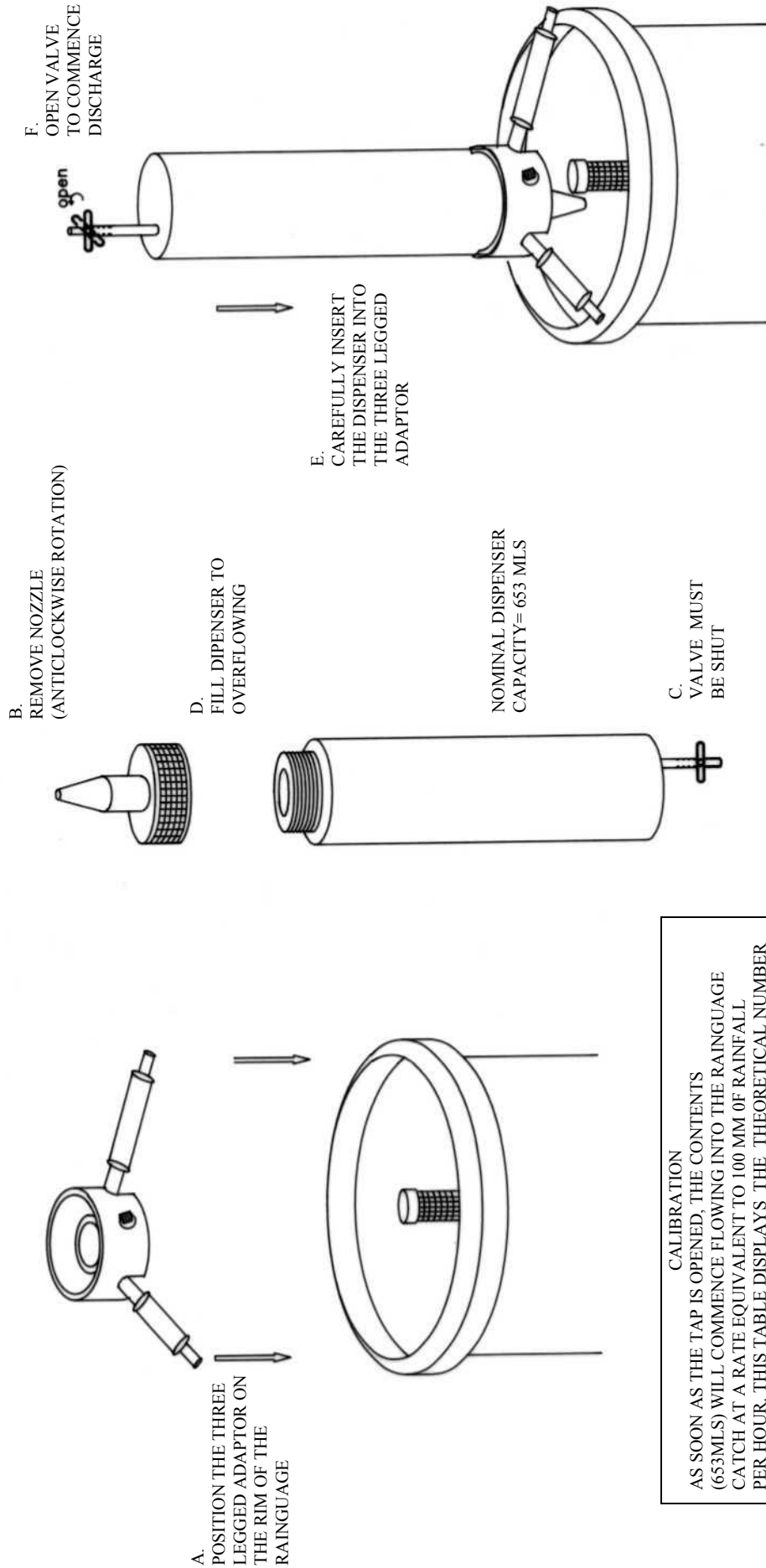

CALIBRATION

AS SOON AS THE TAP IS OPENED, THE CONTENTS (653MLs) WILL COMMENCE FLOWING INTO THE RAINGUAGE CATCH AT A RATE EQUIVALENT TO 100 MM OF RAINFALL PER HOUR. THIS TABLE DISPLAYS THE THEORETICAL NUMBER OF BUCKET TIPS THAT SHOULD BE ACHIEVED.

THEORETICAL NUMBER OF TIPS		
BUCKET SIZE	200 MM CATCH	203 MM (80) CATCH
0.2 MM	103.9	100.9
0.5 MM	41.6	40.4
1.0 MM	20.8	20.2
0.01 INCH	81.8	79.4

IF THE OBSERVED RESULTS ARE UNACCEPTABLE THEN REFER TO THE RAINGUAGE INSTRUCTION MANUAL FOR APPROPRIATE ADJUSTMENTS

**INSTRUCTION FOR TIPPING BUCKET**  
**RAINGUAGE FCD FIELD CALIBRATOR**

# HYDROLOGICAL SERVICES

---